



Instruction Manual

Alfa Laval Rotacheck+ & Rotacheck Basic



Covering: Standard Machines
Machines delivered with ATEX Certification in accordance with Directive 2014/34/EU
TE91A664
First published: 2012-09

ESE02219-EN6 2018-11

Original manual

The information herein is correct at the time of issue but may be subject to change without prior notice

1. EC/EU Declaration of Conformity	4
2. Safety	5
2.1. Important information	5
2.2. Warning signs	5
2.3. Safety precautions	6
3. Introduction	7
3.1. Introduction	7
3.2. Patents and Trademarks	8
3.3. ATEX Marking	9
4. Installation	10
4.1. General Description	10
4.2. Specific Conditions for Safe Use in Accordance with ATEX Certification	11
4.3. Mounting position of Hygienic Tank Connection	12
4.4. Overview of installation instructions	13
4.5. Product dimensions	14
4.6. Mounting Rotacheck on tank – step 1	15
4.7. Connect electrical cable - step 2	16
4.8. Digital version - PNP	18
4.9. Calibrate - step 3 - Rotacheck Basic	19
4.10. Calibrate - step 3 – Rotacheck+ (with TEACH)	20
4.11. Recycling information	23
5. Troubleshooting	24
5.1. No light	24
5.2. Red light	24
5.3. Red/Yellow flashing light	24
5.4. Other failure modes	24
6. Technical Data	25
6.1. Technical data	25
7. Parts Lists and Drawing	26
7.1. Parts drawing and list	26
7.2. Optional parts	28
8. Short functional guide	30
8.1. LED signals	30
8.2. Push button (PB) operation	30
9. General Information	31
9.1. Service & Repair	31
9.2. Warranty	31
9.3. How to contact Alfa Laval Kolding A/S	31

1 EC/EU Declaration of Conformity

The Designated Company

Alfa Laval Kolding A/S

Company Name

Albuen 31, DK-6000 Kolding, Denmark

Address

+45 79 32 22 00

Phone No.

hereby declare that

Rotacheck+ & Rotacheck Basic

Designation

Unit for rotation validation of tank cleaning machines

Type

is in conformity with the following directives with amendments:

Low Voltage Directive (LVD) 2006/96/EF Directive 2006/95/EC on low voltage

EMC Directive 2014/30/EU

ROHS Directive 2002/95/EEC

Machinery Directive 2006/42/EC

Equipment Explosive Atmospheres (ATEX) Directive 2014/34/EU Annex III

EN 60079-0:2009, EN 60079-11:2007, EN 60079-15:2010, EN 60079-26:2007 & EN 60079-31:2009

EC Type Examination Certificate no. IBExU12ATEX1125 X

Marking:  II 1/3G Ex ia/nA IIB T4/T3 Ga/Gc

Marking:  II 1/3D Ex ia/tc IIB T40°C Da/Dc

IBExU Institut für Sicherheitstechnik GmbH, Certification Body number 0637. Fuchsmühlenweg 7, 09599 Freiberg, Germany

The person authorised to compile the technical file is the signer of this document.

Global Product Quality Manager
Pumps, Valves, Fittings and Tank Equipment

Title

Lars Kruse Andersen

Name



Signature

Kolding

Place

2017-03-01

Date

(This Declaration of Conformity replaces Declaration of Conformity dated 2014-10-17)



Unsafe practices and other important information are emphasized in this manual. Warnings are emphasized by means of special signs. Pay special attention to the instructions below in order to avoid serious personal injury or damage to the top unit.

2.1 Important information

Always read the manual before using the Rotacheck+ or the Rotacheck Basic.

WARNING

Indicates that special procedures must be followed to avoid serious personal injury.

CAUTION

Indicates that special procedures must be followed to avoid damage to the Rotacheck + or the Rotacheck Basic.

NOTE

Indicates important information to simplify or clarify procedures.

2.2 Warning signs

General warning:



Dangerous electrical voltage:



Caustic agents:



2 Safety

Unsafe practices and other important information are emphasized in this manual. Warnings are emphasized by means of special signs. Pay special attention to the instructions below in order to avoid serious personal injury or damage to the top unit.

2.3 Safety precautions

Installation:

Always read the technical data thoroughly. (See chapter 6.1 Technical data page 25).

Always use a power supply that complies with IEC/EN60950-1 or IEC/EN61010-1 standard and limited-energy circuit requirements.



Operation:

Always read the technical data thoroughly. (See chapter 6.1 Technical data page 25).

Never touch the Rotacheck or the connected equipment when processing hot liquids or when sterilizing.

Always handle lye and acid with great care.



Transportation:

Always remove the protective cap directly before starting assembly to avoid damaging the Rotacheck. The delivered protective cap has to be stored.

Always place the protective cap on the Rotacheck again immediately after disassembly.

Always make sure that all connections are disconnected before attempting to remove the Rotacheck from the installation.

Always ensure adequate fixing of the Rotacheck during transportation – if specially designed packaging material is available it must be used.

3.1 Introduction

This manual has been prepared as a guide for installing, operating and maintaining your Alfa Laval Rotacheck Basic and Rotacheck+. Should you require further assistance, our Technical Sales Support department and worldwide net of sales offices are pleased to help you.

Important information: Before installing the Alfa Laval Rotacheck Basic and Rotacheck+ and setting it into operation, carefully read the safety precautions (page 6) and the specific conditions for safe use in accordance with ATEX Certification Directive Directive 2014/34/EU (page 11) and take all necessary precautions according to your application and local regulations.



NOTE

The illustrations and specifications contained in this manual were effective at the date of printing. However, as continuous improvements are our policy, we reserve the right to alter or modify any unit specification on any product without prior notice or any obligation

The English version of the instruction manual is the original manual. We make reservations in regard to possible mistranslations in language versions of the instruction manual. In case of doubt, the English version of the instruction manual applies.

3 Introduction

3.2 Patents and Trademarks

This Instruction Manual is published by Alfa Laval Kolding A/S without any warranty. Improvements and changes to this Instruction Manual may at any time be made by Alfa Laval Kolding A/S without prior notice. Such changes will, however, be incorporated in new editions of this Instruction Manual.

Alfa Laval, Kolding A/S. All rights reserved.

The Rotacheck product has patents in the EPO member states and in other countries. The Alfa Laval logotype is a trademark or a registered trademark of Alfa Laval Corporate AB. Other products or company names mentioned herein may be the trademarks of their respective owners. Any rights not expressly granted herein are reserved.

If ordered with ATEX certificate

3.3 ATEX Marking

The Alfa Laval Rotacheck+ and Rotacheck Basic is certified as category I components. The certification is carried out by the certified body IBExU Institut für Sicherheitstechnik GmbH, who has issued the certificate no. IBExU12ATEX1125 X. The marking on the ATEX certified Alfa Laval Rotacheck+ and Rotacheck Basic is as follows:



Changes to the Alfa Laval Rotacheck+ and Rotacheck Basic are not allowed without approval by the person responsible for the ATEX certification at Alfa Laval Kolding A/S. If changes are made – or spare parts other than Alfa Laval original spare parts are used - the EC Type Examination certification (the ATEX Directive) is no longer valid.

Important ATEX information: See also page 11 regarding specific conditions for safe use in accordance with the ATEX certification, Directive 2014/34/EU.



4 Installation

4.1 General Description

Concept

Rotacheck is a control and validation unit for tank cleaning machines, in particular Rotary Jet Heads. Communication is digital PNP to and from a PLC.

Rotacheck consists of a sensor unit with its sensing device located on the inside of a processing tank. The sensor is connected to a sensor board where the signal is processed and communicated to the PLC.

The Alfa Laval Rotacheck is ideal for validation of the cleaning process inside any hygienic tank cleaned with a rotary Jet head. It is available in two versions: Rotacheck+ with a built-in validation function and Rotacheck Basic with standard functionality.

The hygienic installation is guaranteed by using the new Alfa Laval full flushable connection, certified by 3A and EHEDG.

Rotacheck is designed for use in Ex areas.

Working principle

Rotacheck+

The Alfa Laval Rotacheck+ is based on an Alfa Laval invention which features unique teach-in and monitoring functions. The teach-in function is used during a reference CIP run. During this first CIP run the Rotacheck+ stores time and pressure data from the cleaning process.

In terms of cleaning jet intensity on the tank wall (hits) and the time between the hits from the water jet the reference data represents a unique pattern for the specific process. Status is shown by digital PLC output as well as a visual light indication.

Afterwards, during production, the feedback from the integrated pressure transducer is continuously compared to the stored acceptance window, and the Rotacheck+ digitally outputs a validated feedback. This digital feedback clearly indicates the state that the cleaning process is in.

The system feedback has 3 different outputs.

Rotation OK output: on when rotation is within acceptance window

Alarm output: on when cleaning is out of teach-in acceptance window

IDLE output: on when cleaning is not performed

Rotacheck Basic

The Rotacheck Basic registers when the sensor head is hit by the cleaning jet. Status is shown by digital PLC output as well as a visual light indication.

The system feedback has 3 different outputs.

Hit output: on when sensor head is hit by cleaning jet

Alarm output: on in case of unit failure or constant hit (cleaning device error)

IDLE output: on when cleaning is not performed

4.2 Specific Conditions for Safe Use in Accordance with ATEX Certification

Directive 2014/34/EU

Warning: Surface temperature

The surface temperature must not exceed 140°C.



Warning: Use in explosive atmosphere

The device may be used in an explosive atmosphere, the apparatus of category 1 requires only operate if there are atmospheric conditions (temperature of -20°C to +60°C, pressure of 0.8 bar to 1.1 bar).



4 Installation

4.3 Mounting position of Hygienic Tank Connection

In order to ensure optimum signal quality, the Rotacheck should be placed with an offset to the downpipe as close as possible to the offset of the jets nozzles of the tank cleaning machine in use.

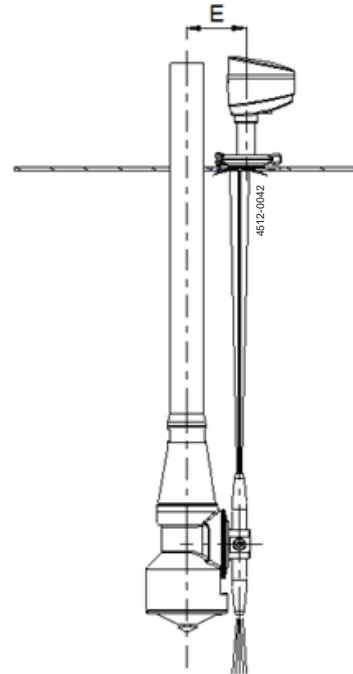

Examples of different offset:

Tank cleaning machine type	Offset (E)
Toftejorg TJ20G	75 mm
Toftejorg TJ40G	91 mm
Toftejorg TZ-74	78 mm
Toftejorg TZ-79	98 mm
Toftejorg MultiJet 65 with 4 nozzles	98 mm
Toftejorg TZ-89	50-90 mm (depending on size of mounting connection)
Toftejorg TZ-750	115 mm
Toftejorg MultiJet 65 with 2 nozzles	115 mm

Deviations from the above given positions may work, but will influence the signal quality.

It is not recommended to go closer to the centerline, as there is a risk of having no signal. If the Rotacheck Sensor is placed further away from the centerline, the number of times it is directly hit by a jet is reduced.

4.4 Overview of installation instructions

Step 1

Mount Rotacheck on tank

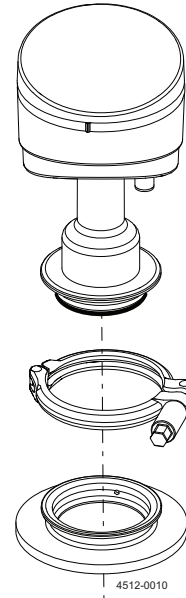

Step 2

Connect electrical cable

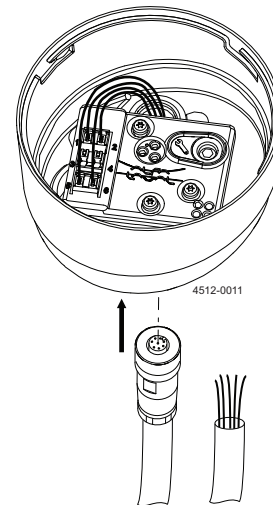

Step 3

Calibrate.

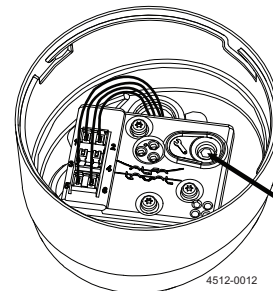

4 Installation

4.5 Product dimensions

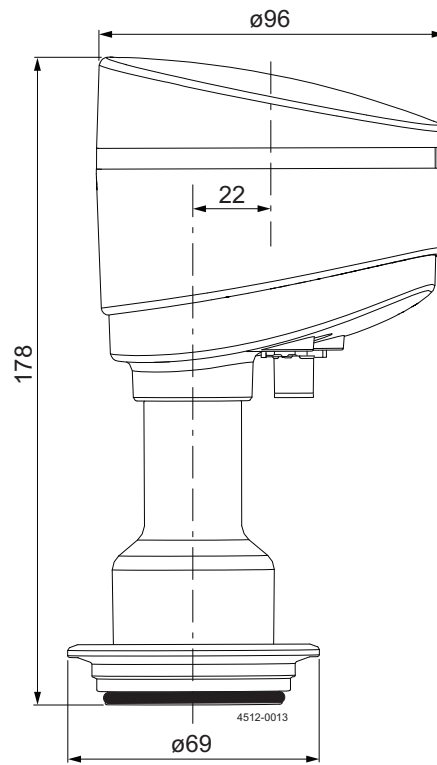

Weight: 0.6 kg

4.6 Mounting Rotacheck on tank – step 1

Step 1

Remove protective cap from sensor.
Check that o-ring on sensor head is in place.

Step 2

Mount Rotacheck on flange.

Step 3

Tighten clamp ring.

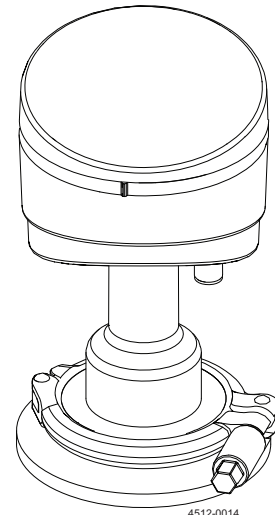

4 Installation

4.7 Connect electrical cable - step 2

WARNING

Special considerations for use in hazardous areas

For the installation, maintenance and cleaning of the device, you must absolutely observe the relevant regulations and stipulations on explosion protection (EN 60079-14 and EN60079-17) as well as the occupational safety provisions.

The device is designed acc. to standards:

EN60079-0:2009, EN60079-11:2007, EN60079-15:2010, EN60079-26:2007 and EN60079-31:2009.

Cable gland version

Step 1

Remove the prism/top cover by turning the prism/top cover counter-clockwise. Counterhold on the base part. When the mark on the prism (J) is aligned with the open padlock symbol (K), the prism/top cover can be lifted off.

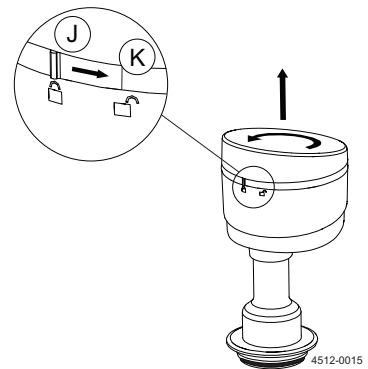

Step 2

Install the cable in the cable gland (M) and tighten nut.

NOTE!

Cable connection:

Cable gland: M16 (ø5-ø8)

Max. wire diameter: 1.0 mm² (AWG 18)

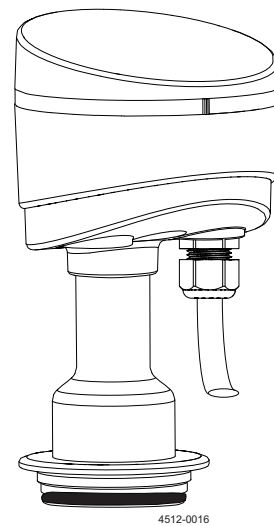

If the cable gland comes loose from the control head during installation, it must be secured with a tightening torque of 4 Nm.

Step 3

Connect wires to board according to illustration number 4512-0018 on page 18.

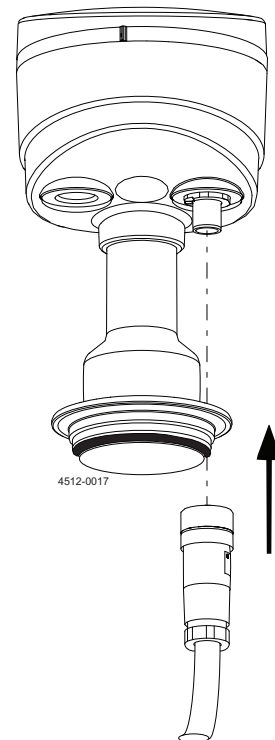

M12 plug version

Step 1

Connect the electrical M12 plug to the connector on Rotacheck.
Tighten the knurled nut.
See wiring diagram on page 18.

4 Installation

4.8 Digital version - PNP

Supply voltage	
Supply voltage	24 Vdc \pm 10%
Max. power consumption of the sensor unit	
Power consumption max	70 mA
Output signals from the sensor unit to the connected digital interface (PLC)	
Outputs (Hit/Rotation OK, Alarm, Idle)	Logic PNP
Max. current per output	50 mA

Electrical connection on PCB

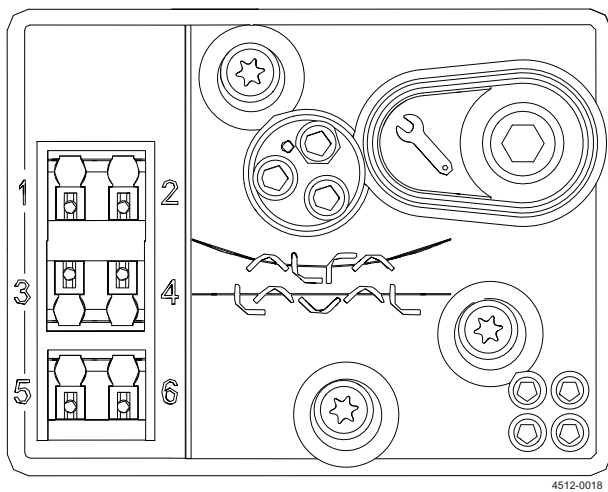

Sensor board		
Designation		No.
Supply 24 VDC		1
Supply 0 VDC		2
Feedback Idle		3
Feedback Hit/Rotation OK		4
Alarm		5
Activate teach (Rotacheck+ only)		6

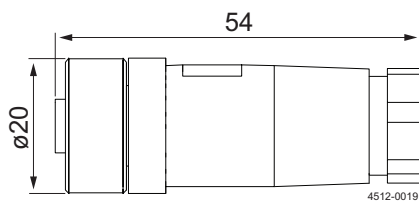

M12 connector		
Designation		No.
Supply 24 VDC		1
Supply 0 VDC		3
Feedback Idle		5
Feedback Hit/Rotation OK		2
Alarm		6
Activate teach (Rotacheck+ only)		4

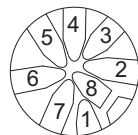

View from mounting side

Alfa Laval part number 9611995257 (not part of delivery)

4.9 Calibrate - step 3 - Rotacheck Basic

Step 1

The Rotacheck Basic must be fully installed:

- Mechanically
- Electrically

The unit will flash green on power up and perform an internal calibration after 5 sec.

The unit is ready to use when the green LED lights steadily.

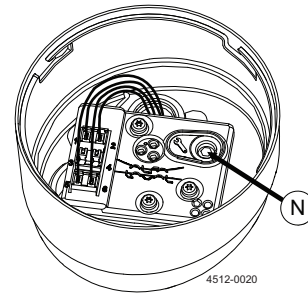

Optional re-calibration

Push the blue button (N) on the sensor unit until you see a yellow flash.

The Rotacheck Basic will automatically re-calibrate.

Step 2

(If unit has been opened)

Put the prism/top cover back on the base part by pushing it down when the mark on the prism (J) and the open padlock (K) are aligned. Then turn it clockwise towards the closed padlock (L) to secure. Counterhold on the base part.

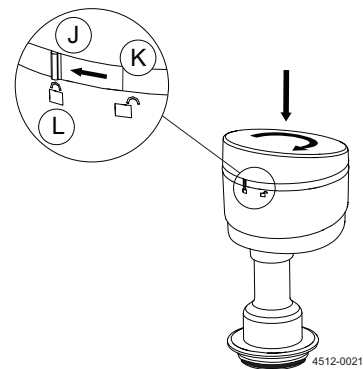

Operating LED and PLC feedback

Rotacheck Basic status	LED feedback	PLC feedback
Calibration	Green, flashing	No feedback
Idle	Green, steady	On
Hit	Yellow, 1 sec	On, 1 sec
Alarm*	Red, steady	On

* Unit failure or constant hit (cleaning device error)

4 Installation

4.10 Calibrate - step 3 – Rotacheck+ (with TEACH)

Step 1

The Rotacheck Basic must be fully installed:

- Mechanically
- Electrically

Usage before TEACH has been performed:
Rotacheck+ where TEACH has not yet been performed, will show similar functionality as Rotacheck Basic, except that Idle mode is indicated by a flashing (mostly on) green LED.

Step 2

Calibration - TEACH

Method 1: Auto-TEACH

- Ensure that cleaning machine is commissioned, and its performance is approved by end-user
- Install Rotacheck+, ensure “green LED is flashing (mostly on)”
- Open top cap of Rotacheck+
- Start cleaning machine

Enable TEACH by pressing the blue button on sensor board for 1 sec and release after 1 yellow LED flash is seen.

Duration of TEACH is preset to 16 minutes.

- A red LED is flashing to indicate TEACH ongoing
- Let the cleaning process run for at least 16 minutes (the Rotacheck+ will teach-in cleaning pattern during this time)
- Every sensor hit during TEACH is indicated by a yellow LED flash
- Rotacheck+ will light up green when teach-in is finished

The TEACH sequence is terminated if no sensor hits are registered within a 4 min. interval.

NOTE

Longer TEACH intervals may be necessary in some cases, to secure proper calibration data. For example in case of unfavourable placement of Rotacheck, see guidelines for installation, page 12. In these cases manual calibration according to method 2 is recommended.

Method 2: Manual TEACH

- Ensure that cleaning machine is commissioned, and its performance is approved by end-user
- Install Rotacheck+, ensure “green LED is flashing (mostly on)”
- Start cleaning machine

Enable TEACH by activating input on sensor board, connector number 6, see table page 18.

TEACH will be performed as long as the input is activated, up to maximum 60 minutes.

For proper calibration TEACH must run for sufficiently long time. This is application dependant and must be determined on-site.

- A red LED is flashing to indicate TEACH ongoing
- Let the cleaning process run for at least 16 minutes (the Rotacheck+ will teach-in cleaning pattern during this time)
- Every sensor hit during TEACH is indicated by a yellow LED flash
- Let the cleaning process run for sufficient time (the Rotacheck+ will teach-in cleaning pattern during this time)
- De-activate TEACH input on sensor board, terminal 6 after the desired time is elapsed.
- Rotacheck+ will light up green when teach-in is finished

Step 3

Operation after TEACH

If TEACH is completed, Rotacheck+ will enter Idle mode.

- When cleaning is ongoing, Rotacheck+ compares cleaning parameters to the reference cycle.
- If parameters are within the calibrated values, a "Rotation OK" feedback is initiated
- If parameters are outside the calibrated values, the alarm function is entered.

NOTE

If it – due to special circumstances - proves too difficult to make a proper calibration, Rotacheck+ can be reset to "1st power up mode".

This is done by pressing the Push Button for 10 seconds, and release when 3 yellow LED flashes are seen.

After Rotacheck+ is reset it will function similar to a Rotacheck Basic, but with a flashing green LED (mostly on), when idle.

4 Installation

Operating LED and PLC feedback

Unit status	LED feedback	PLC feedback
OPERATION		
Self calibration on 1 st power up (0-5 sec.)	Green flashing(50/50 on /off)	No feedback
Idle (before TEACH)	Green flashing (mostly on)	Idle
Idle (after TEACH)	Green	
Sensor hit (before TEACH)	Yellow - 1 sec.	Hit/Rotation OK - 1 sec
Alarm*	Red	Alarm
Alarm, sensor not connected	Red/Yellow flashing	Alarm
Rotation OK (after TEACH)	Yellow flashing (slowly)	Hit/Rotation OK
Sensor hit (after TEACH)	Yellow – 3 flashes	Hit/Rotation OK
End of cleaning sequence**	Red - 3 sec.	Alarm - 1 sec.
TEACH		
TEACH ongoing	Red flashing	No feedback
Sensor hit during TEACH	Yellow - 1 sec.	No feedback
Termination of TEACH***	Yellow - 1 flash	No feedback

*Constant sensor hit or max. tank pressure is exceeded

**If no sensor hits are recorded during the maximum interval set by TEACH function

***Finalization of TEACH after preset time or if TEACH input is de-activated. Max. duration of TEACH is 20 min. where after Rotacheck+ automatically sets up reference data

Back to 1st power up mode (factory settings)

Rotacheck can be brought back to 1st power up mode by pressing the blue pushbutton for 10 seconds and release when 3 yellow LED flashes are seen.

Feedback test mode – Rotacheck+ (with TEACH) only

Feedback test mode is a function that can be enabled after installation to validate proper function of the external wiring. When the mode is entered, Rotacheck+ automatically switches PLC and LED outputs in 5 seconds intervals.

Enter Feedback test mode:

Press the blue button on the sensor board and release after 5 seconds when 2 Yellow LED flashes are seen.

This mode can only be entered from 1st power-up or Idle modes.

Exit Feedback test mode:

Feedback test mode automatically terminates after 3 minutes.

The function can also be terminated by shortly pressing the blue button on the sensor board.

Exit is indicated by 2 yellow flashes.

Unit status is returned to previous state before feedback test mode was enabled.

Feedback test mode LED and PLC feedback

Unit status	LED feedback	PLC feedback
FEEDBACK TEST MODE		
Step 1 (0-5 sec.)	Red	Alarm
Step 2 (5-10 sec)	Yellow	Hit/Rotation OK
Step 3 (10-15 sec.)	Green	Idle
Loop until aborted or timeout after 3 mins.	Yellow – 2 flashes on termination	

4.11 Recycling information

Unpacking

- Packing material consists of plastics and cardboard boxes
- Cardboard boxes can be re-used, recycled or used for energy recovery
- Plastics should be recycled or burnt at a licensed waste incineration plant

Maintenance

In principle, this device is maintenance-free. If desired, the housing of the device can be cleaned using a damp cloth and non-aggressive cleaning solutions, in switched-off state.

Depending on the measuring medium, however, the diaphragm may be polluted or coated with deposit. Is there a pollution tendency of the medium, the user has to determine the appropriate cleaning interval. After placing the device out of service correctly, the diaphragm can usually be cleaned carefully with a non-aggressive cleaning solution and a soft brush or sponge. If the diaphragm is calcified, it is recommended to send the device to Alfa Laval Tank Equipment for decalcification. Please note the chapter "Service/Repair" page 31.

! A false cleaning of the device can cause an irreparable damage on the diaphragm. Therefore never use pointed objects or pressured air for cleaning the diaphragm.

Scrapping

- At end of life, the equipment must be recycled according to the relevant, local regulations. Besides the equipment itself, any hazardous residues from the process liquid must be taken into consideration and dealt with in a proper manner. When in doubt, or in the absence of local regulations, please contact your local Alfa Laval sales company.

Disposal

- The device has to be disposed of according to the European Directives 2002/96/EG and 2003/108/EG (on waste electrical and electronic equipment). It is prohibited to place electrical and electronic equipment in domestic refuse!



Depending on the used medium, deposit on the device may cause danger for the user and the environment. Comply with adequate precautions for purification and dispose of it properly.

5 Troubleshooting

5.1 No light

- Check that the unit is connected to electrical power.
 - Press the blue button on the sensor board shortly to restart unit.
 - Power down the unit and reconnect power again after 5 seconds.
 - If problem persists, please contact Alfa Laval.
-

5.2 Red light

Constant red LED light is an indication of an alarm condition. Such condition can be "Rotation not OK" (Rotacheck+), or if there is a constant jet impact on the sensor (Rotacheck Basic, Rotacheck+).

- Check if there is a problem with the cleaning process.
 - Check if the tank pressure is exceeding the max. rating.
 - Alternatively restart unit by shortly pressing the blue button on the sensor board.
 - Recalibrate TEACH (Rotacheck+) if necessary by following the instructions.
 - If problem persists, please contact Alfa Laval.
-

5.3 Red/Yellow flashing light

Red/Yellow flashing light indicates sensor malfunction or lost internal connection between sensor board and sensor.

- Press the blue button on the sensor board shortly to restart unit, or power down the unit and reconnect power again after 5 seconds.
 - If problem persists, please contact Alfa Laval.
-

5.4 Other failure modes

- Check the unit for visible damage.
 - Press the blue button on the sensor board shortly to restart unit.
 - Power down the unit and reconnect power again after 5 seconds.
 - Recalibrate TEACH (Rotacheck+) if necessary by following the instructions.
 - If problem persists, please contact Alfa Laval.
-

6.1 Technical data

Electrical data	
Power supply Power consumption max. Outputs (OK/hit, Alarm, Idle) Electrical connection Cable- ϕ and wire- ϕ - for Cable gland (M16) - for M12 connector Short circuit and brownout protection Surges immunity	24 Vdc \pm 10% 70 mA Logic PNP Cable gland or M12 connector, ϕ 5- ϕ 8mm, max. 1,0mm ² (AWG 18) ϕ 6- ϕ 8mm, max. 0,5mm ² (AWG 20) EN 61131-2 EN 61000-4-5
Special conditions for use in hazardous areas	
<p>Rotacheck is approved in accordance with ATEX directive 94/9/EC, for use in Zone 0/20 in the product wetted area and Zone 2/22 in the non-product wetted area.</p> <p>Ex identification: II 1/3G Ex ia/nA IIB T4/T3 Ga/Gc II 1/3D Ex ia/tc IIIB T130 °C Da/Dc</p> <p>Special conditions for safe use: T4 for media temperatures <85°C T3 for media temperatures <140°C</p> <p>Fall height 40 cm is utilized in impact test of Rotacheck with M12 cable connector plug. Permissible temperatures for environment for use in Zone 0 (Patm 0,8 to 1,1 bar): -10°C to 60°C</p> <p>WARNING!: Rotacheck must not be separated when energized</p>	
Physical data	
Protection class	IP66 and IP67
Pressure rating of sensor	
Pressure overload on diaphragm	15 bar
Max. working pressure in tank while performing monitoring	0.3 bar
Materials	
Product wetted steel parts	AISI 316L
Field house	Polymer PA12, reinforced
Product wetted seals	EPDM
Other seals	NBR
Surface roughness, product wetted parts	Ra 0,5 μ m
Operating temperature	
Wetted parts	-40°C to 125°C (140°C < 1 hour)
Field house	-10°C to 60°C
Weight	
Weight	Approx. 600 gr.
Process connection	
Alfa Laval Hygienic Tank Connection (HTC)	

7 Parts Lists and Drawing

7.1 Parts drawing and list

Parts Drawing

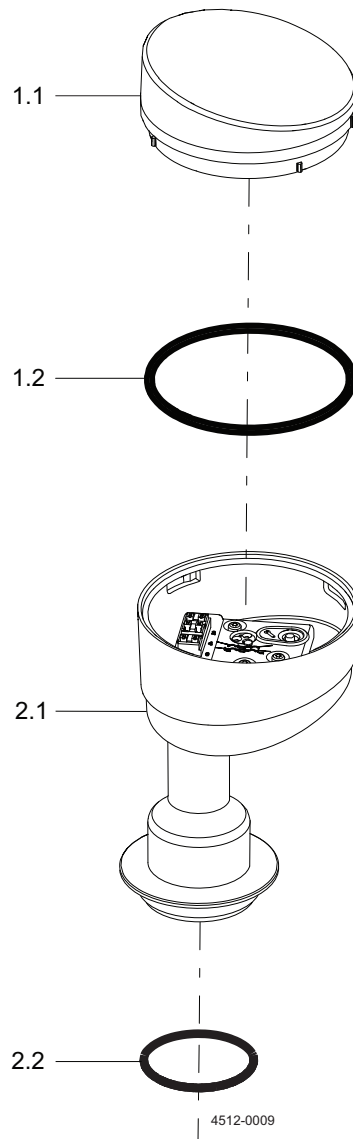

Parts list

Pos.	Qty	Denomination
1	1	Top cover/prism and o-ring assembly
1.1	-	Top cover/prism assembly
1.2	-	O-ring for top cover
2	1	Sensor unit with o-ring
2.1	-	Sensor unit
2.2 <input type="checkbox"/>	-	O-ring
<input type="checkbox"/>	-	O-ring (Q-doc version)
<input type="checkbox"/>	-	O-ring set (10 pcs.) EPDM

Configuration according to delivery note/order.

7 Parts Lists and Drawing

7.2 Optional parts

Optional Parts Drawing

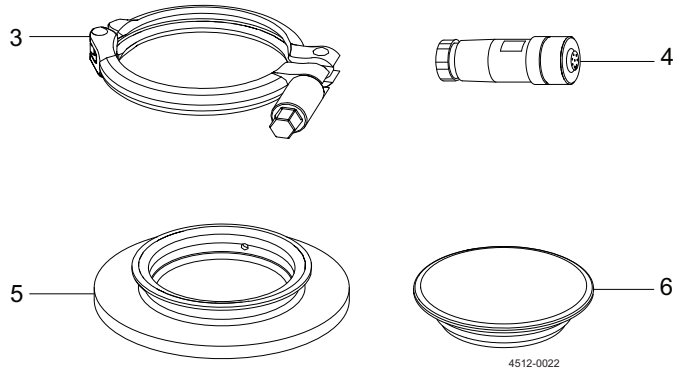

Parts list

Pos.	Qty	Denomination
3	1	Clamp ring
4	1	M12 connector
5 <input type="checkbox"/>	1	Tank flange, Hygienic tank connection HTC
<input type="checkbox"/>	1	Tank flange, Hygienic tank connection HTC (Q-doc version)
6 <input type="checkbox"/>	1	Blind cap with o-ring
<input type="checkbox"/>	1	Blind cap with o-ring (Q-doc version)

Configuration according to delivery note/order.

8 Short functional guide

8.1 LED signals

Colour	Signal	Explanation
Green	Flashing (50/50%)	Initial calibration
Green	On	Idle
Green	On/off (95/5%)	First power-up (Rotacheck+ before Teach)
Yellow	Yellow LED flash (1s)	Sensor hit (Rotacheck basic or Rotacheck+ before Teach)
Yellow	On/off (50/50%)	Operation In window (Rotacheck+)
Yellow	3 short flashes	Sensor hit during operation In window (Rotacheck+)
Yellow	1 short flash	Termination of Teach (Rotacheck+)
Red	Steady on	Alarm
Red/Yellow	Flashing	Sensor alarm
Red/Yellow/Green	Switching every 5 seconds	Feedback Test mode (Rotacheck+)

8.2 Push button (PB) operation

PB Operation	Signal	Explanation
Press shortly	Flashing green LED (5s)	System restart
Press 1 second	1 Yellow LED flash	Enable Teach (Rotacheck+)
Press 5 seconds	2 Yellow LED flashes	Enable feedback test mode (Rotacheck+)
Press 10 seconds	3 Yellow flashes	Back to first power up mode (Rotacheck+)

9.1 Service & Repair

Upon every return of a product, no matter if for modifications or repair, it is necessary to contact your local Alfa Laval office to guarantee a quick execution of your request.

You will receive instructions regarding the return procedure from your local Alfa Laval office. Be sure to follow the instructions closely.

9.2 Warranty

The warranty conditions are subject to the legal warranty period of 12 months from the date of delivery. In case of improper use, modifications of or damages to the device, we do not accept warranty claims. Damaged devices will also not be accepted. Furthermore, defects due to normal wear are not subject to warranty services.

9.3 How to contact Alfa Laval Kolding A/S

For further information please feel free to contact:

Alfa Laval Kolding A/S

31, Albuen - DK 6000 Kolding - Denmark

Registration number: 30938011

Tel switchboard: +45 79 32 22 00 - Fax switchboard: +45 79 32 25 80

www.toftejorg.com, www.alfalaval.dk - info.dk@alfalaval.com

Contact details for all countries are continually updated on our websites

How to contact Alfa Laval

Contact details for all countries are continually updated on our website.

Please visit www.alfalaval.com to access the information directly.

© Alfa Laval Corporate AB

This document and its contents is owned by Alfa Laval Corporate AB and protected by laws governing intellectual property and thereto related rights. It is the responsibility of the user of this document to comply with all applicable intellectual property laws. Without limiting any rights related to this document, no part of this document may be copied, reproduced or transmitted in any form or by any means (electronic, mechanical, photocopying, recording, or otherwise), or for any purpose, without the expressed permission of Alfa Laval Corporate AB. Alfa Laval Corporate AB will enforce its rights related to this document to the fullest extent of the law, including the seeking of criminal prosecution.