



Spare Parts

Alfa Laval IM 20 Rotary Jet Mixer



EPS00178-EN10 2020-07

Original manual

Table of contents

The information herein is correct at the time of issue but may be subject to change without prior notice

1. Alfa Laval IM 20 Rotary Jet Mixer Part drawings, part lists, service kits & tools	4
2. Alfa Laval IM 20 previous version Machine design obsolete December 29, 2010. Below serial # 1012-002	12

Machine with 2 nozzles

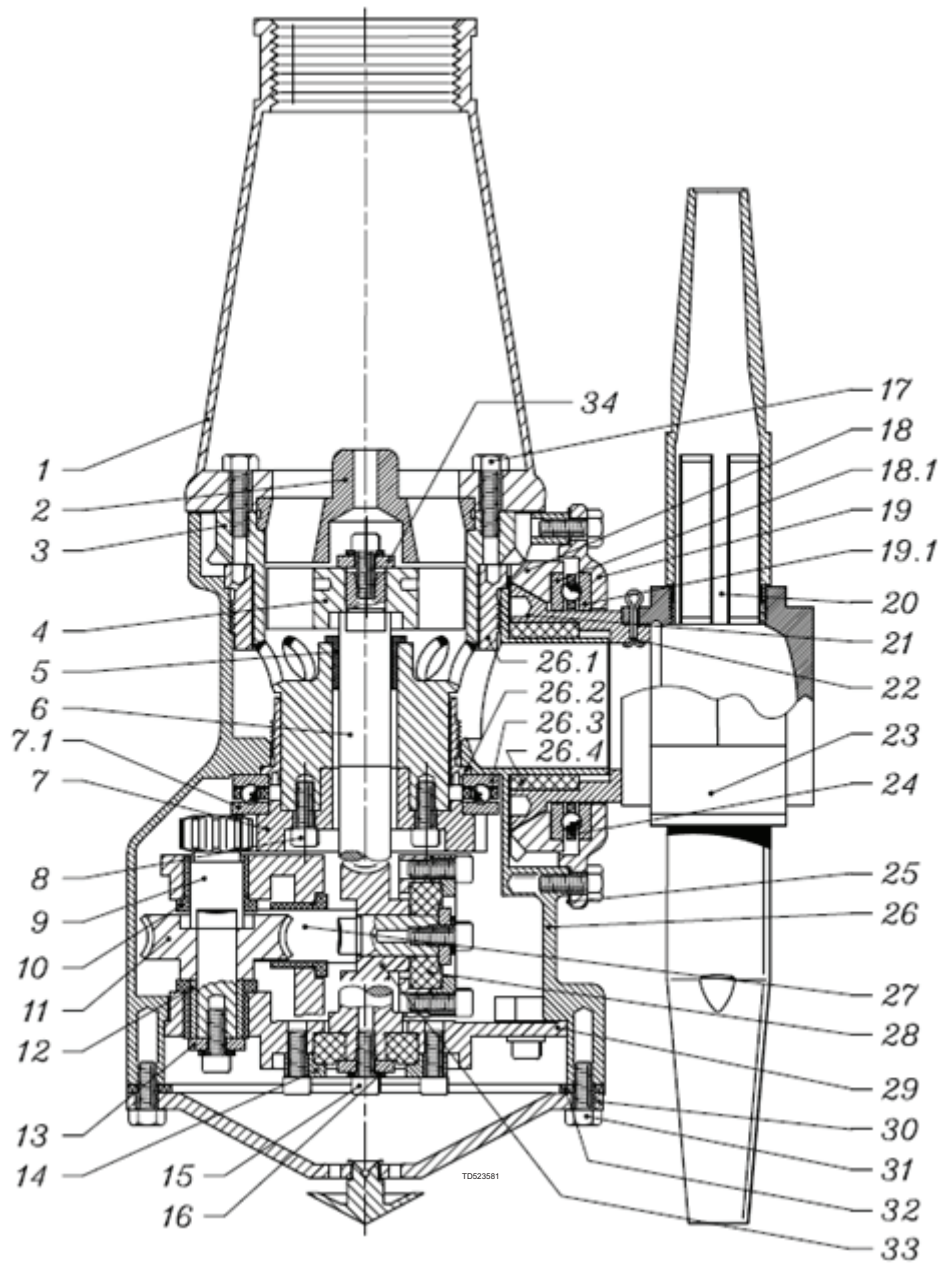

Alfa Laval IM 20 Rotary Jet Mixer
Part drawings, part lists & tools

Pos	Qty	Denomination	Item no.	Material	Material	Remark
Machine with 2 nozzles						
1	<input type="checkbox"/>	1 Top cone, 2" BSP	TE22D500	Stainless steel		Spare part
	<input type="checkbox"/>	1 Top cone, 2" NPT	TE22D501	Stainless steel		Spare part
2		1 Guide ring, 0%	TE1030	Stainless steel		Spare part
3		1 Stem	TE32B526	Stainless steel		Spare part
4		1 Impeller, 100%	TE32B508	Stainless steel		Spare part
5	◆○	1 Main bush	TE32B576	Polymer		Wear part
6	◆○	1 Turbine shaft	TE32B511	Stainless steel		Wear part
7		1 Gear wheel w. ball race	TE32B303	Stainless steel		Spare part
7.1	◆○	1 Ball race	TE32B510	Stainless steel		Wear part
8		6 Screw	TE120	Stainless steel		Spare part
9		1 Pinion	TE114	Stainless steel		Spare part
10	◆○	3 Collar bush	TE22A586	Polymer		Wear part
11	◆○	1 Worm wheel	TE22A365	Polymer		Wear part
12		1 Journal	TE117	Stainless steel		Spare part
13		9 Spring washer	TE156	Stainless steel		Spare part
14		2 Bearing cover	TE531	Stainless steel		Spare part
15		17 Screw	TE118	Stainless steel		Spare part
16		3 Washer	TE619A	Stainless steel		Spare part
17		8 Screw	TE902H	Stainless steel		Spare part
18		1 Bevel gear with ball race	TE32B307	Stainless steel		Spare part
18.1	◆○	1 Ball race	TE32B510	Stainless steel		Wear part
19		1 Hub cover with ball race	TE32B306	Stainless steel		Spare part
19.1	◆○	1 Ball race	TE32B510	Stainless steel		Wear part
20	<input type="checkbox"/>	2 Nozzle, ø12	TE50C012	Stainless steel		Spare part
	<input type="checkbox"/>	2 Nozzle, ø13	TE50C013	Stainless steel		Spare part
	<input type="checkbox"/>	2 Nozzle, ø14	TE50C014	Stainless steel		Spare part
	<input type="checkbox"/>	2 Nozzle, ø15	TE50C015	Stainless steel		Spare part
21		1 Hub conical part	TE32B534	Stainless steel		Spare part
22		1 Cotter pin	TE448	Stainless steel		Wear part
23		1 Hub nozzle part for 2 nozzle	TE624215	Stainless steel		Wear part
24	<input type="checkbox"/> ◆	2 Ball retainer with balls	TE32B302	Polymer	Ceramics	Wear part
	<input type="checkbox"/> ○	2 Ball retainer with balls	TE126S	Polymer	Stainless steel	Wear part
25		1 Hub gasket	TE22D553	Polymer	Elastomer	Spare part
26		1 Body ¹⁾		Stainless steel		N/A
26.1		1 Main collar upper	TE32B577	Polymer		Wear part
26.2		1 Main collar lower	TE32B578	Polymer		Wear part
26.3	◆○	1 Ball race	TE32B510	Stainless steel		Wear part
26.4		1 Hub collar	TE32B575	Polymer		Wear part
27	◆○	1 Horizontal shaft	TE128Z	Stainless steel		Wear part
28	◆○	2 Slide bearing	TE22A571	Polymer		Wear part
29		1 Gear frame	TE630	Stainless steel		Spare part
30		1 Bottom cover, compl.	TE32B350	Stainless steel		Spare part
31		12 Screw	TE421H	Stainless steel		Spare part
32		1 Bottom gasket	TE22D554	Polymer	Elastomer	Spare part
33	◆○	1 Worm wheel	TE22A365	Polymer		Wear part
34		1 Washer	TE32B515	Stainless steel		Spare part

Service kits

- ◆ **Service Kit - machines delivered after December 27, 2010.**
From serial no. 1012-002 **TE32B299**
- **Standard service kit for ATEX/IECEx machines** **TE32B29970**

¹⁾ Pos. 26 is not sold as single spare part component. Only sold as part of a machine maintenance/repair order. For further information please contact Alfa Laval Customer Support.

Please note that some of the polymer parts are in PEEK. PEEK is not resistant to concentrated sulfuric acid.

Configuration according to delivery note/order.

Parts marked with ◆ are included in the Standard Service Kit TE32B299

Parts marked with ○ are included in the Standard Service Kit TE32B29970 (ATEX/IECEx)

Alfa Laval IM 20 Rotary Jet Mixer
Part drawings, part lists, service kits & tools

Pos	Qty	Denomination	Item no.	Material	Material	Remark
Machine with 4 nozzles						
1	<input type="checkbox"/>	1 Top cone, 2" BSP	TE22D500	Stainless steel		Spare part
	<input type="checkbox"/>	1 Top cone, 2" NPT	TE22D501	Stainless steel		Spare part
2	<input type="checkbox"/>	1 Guide, 100%	TE603	Stainless steel		Spare part
	<input type="checkbox"/>	1 Guide ring, 0%	TE1030	Stainless steel		Spare part
3		1 Stem	TE32B526	Stainless steel		Spare part
4		1 Impeller, 100%	TE32B508	Stainless steel		Spare part
5	<input checked="" type="radio"/>	1 Main bush	TE32B576	Polymer		Wear part
6	<input checked="" type="radio"/>	1 Turbine shaft	TE32B511	Stainless steel		Wear part
7		1 Gear wheel w. ball race	TE32B303	Stainless steel		Spare part
7.1	<input checked="" type="radio"/>	1 Ball race	TE32B510	Stainless steel		Wear part
8		6 Screw	TE120	Stainless steel		Spare part
9		1 Pinion	TE114	Stainless steel		Spare part
10	<input checked="" type="radio"/>	3 Collar bush	TE22A586	Polymer		Wear part
11	<input checked="" type="radio"/>	1 Worm wheel, w. reinforcement	TE22A365	Polymer		Wear part
12		1 Journal	TE117	Stainless steel		Spare part
13		3 Washer	TE619A	Stainless steel		Spare part
14		2 Bearing cover	TE531	Stainless steel		Spare part
15		17 Screw	TE118	Stainless steel		Spare part
16		9 Spring washer	TE156	Stainless steel		Spare part
17		8 Screw	TE902H	Stainless steel		Spare part
18		1 Bevel gear with ball race	TE32B307	Stainless steel		Spare part
18.1	<input checked="" type="radio"/>	1 Ball race	TE32B510	Stainless steel		Wear part
19		1 Hub cover with ball race	TE32B306	Stainless steel		Spare part
19.1	<input checked="" type="radio"/>	1 Ball race	TE32B510	Stainless steel		Wear part
20	<input type="checkbox"/>	4 Nozzle, ø8	TE50B008	Stainless steel		Spare part
	<input type="checkbox"/>	4 Nozzle, ø9	TE50B009	Stainless steel		Spare part
	<input type="checkbox"/>	4 Nozzle, ø10	TE50B010	Stainless steel		Spare part
	<input type="checkbox"/>	4 Nozzle, ø11	TE50B011	Stainless steel		Spare part
21		1 Hub for 4 nozzle	TE32B536	Stainless steel		Spare part
24	<input checked="" type="checkbox"/>	2 Ball retainer with balls	TE32B302	Polymer	Ceramics	Wear part
	<input type="checkbox"/>	2 Ball retainer with balls	TE126S	Polymer	Stainless steel	Wear part
25		1 Hub gasket	TE22D553	Polymer	Elastomer	Spare part
26		1 Body ¹⁾		Stainless steel		N/A
26.1		1 Main collar upper	TE32B577	Polymer		Wear part
26.2		1 Main collar lower	TE32B578	Polymer		Wear part
26.3	<input checked="" type="radio"/>	1 Ball race	TE32B510	Stainless steel		Wear part
26.4		1 Hub collar	TE32B575	Polymer		Wear part
27	<input checked="" type="radio"/>	1 Horizontal shaft	TE128Z	Stainless steel		Wear part
28	<input checked="" type="radio"/>	2 Slide bearing	TE22A571	Polymer		Wear part
29		1 Gear frame	TE630	Stainless steel		Spare part
30		1 Bottom cover, compl.	TE32B350	Stainless steel		Spare part
31		12 Screw	TE421H	Stainless steel		Spare part
32		1 Bottom gasket	TE22D554	Polymer	Elastomer	Spare part
33	<input checked="" type="radio"/>	1 Worm wheel, w. reinforcement	TE22A365	Polymer	Stainless steel	Wear part
34		1 Washer	TE32B515	Stainless steel	Spare part	

Service kits

- ◆ **Service Kit - machines delivered after December 27, 2010.**
From serial no. 1012-002 **TE32B299**
- **Standard service kit for ATEX/IECEX machines** **TE32B29970**

¹⁾ Pos. 26 is not sold as single spare part component. Only sold as part of a machine maintenance/repair order. For further information please contact Alfa Laval Customer Support.

Please note that some of the polymer parts are in PEEK. PEEK is not resistant to concentrated sulfuric acid.

Configuration according to delivery note/order.

Parts marked with ◆ are included in the Standard Service Kit TE32B299

Parts marked with ○ are included in the Standard Service Kit TE32B29970 ATEX/IECEX

Service intervals

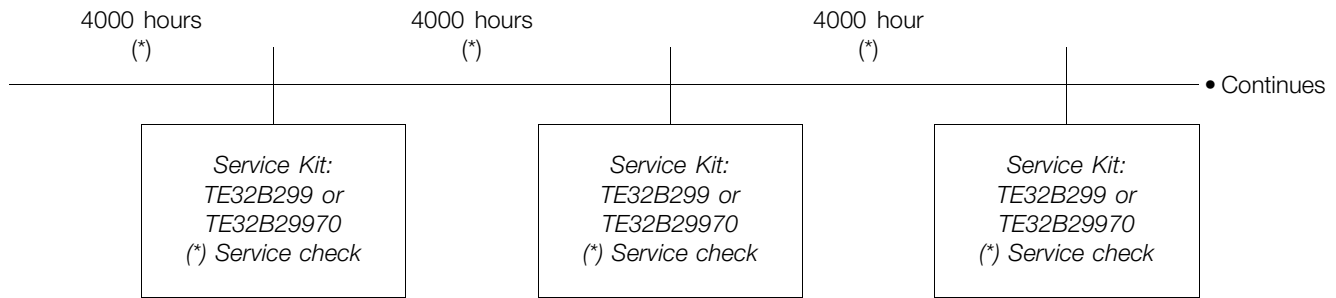

NOTE

The service intervals are recommended on the basis of pure liquids. When liquids contain particles and other kind of abrasives, we recommend shorter service intervals depending on the actual running conditions.

Alfa Laval IM 20 Rotary Jet Mixer
Part drawings, part lists, service kits & tools

Pos	Qty	Denomination	Item no.
Service kits			
		Service kit for IM 20	TE32B299
Consisting of:			
	1	Horizontal Shaft	TE128Z
	2	Worm wheel reinforced	TE22A365
	2	Slide bearing	TE22A571
	3	Collar bush	TE22A586
	2	Ball Retainer with Balls	TE32B302
	4	Ball Race	TE32B510
	1	Turbine Shaft	TE32B511
	1	Main bush for IM	TE32B576

Pos	Qty	Denomination	Item no.
		Service Kit for IM 20 ATEX/IECEX	TE32B29970
Consisting of:			
	1	Horizontal Shaft	TE128Z
	2	Worm wheel reinforced	TE22A365
	2	Slide bearing	TE22A571
	3	Collar bush	TE22A586
	2	Ball Retainer with Balls	TE126S
	4	Ball Race	TE32B510
	1	Turbine Shaft	TE32B511
	1	Main bush for IM	TE32B576

Tools

TE81B031: Pusher for Gear frame

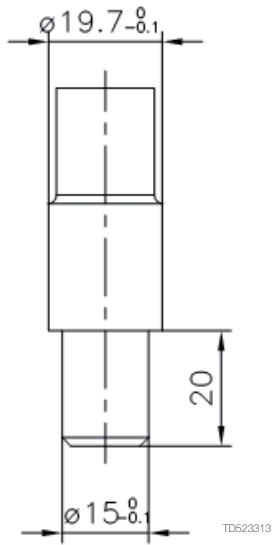

TE81B032: Fixture set f. Gear frame

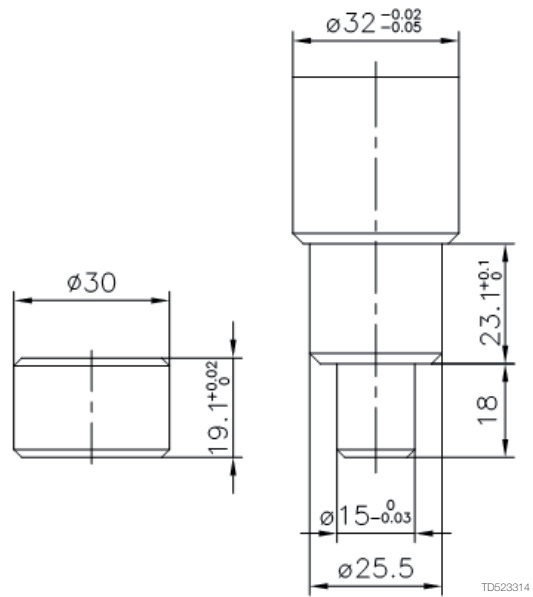

A: TE81B131 Tool for upper collar (2" TCM) compl. - B: TE81B132 Tool for lower collar (2" + 3" TCM) compl.

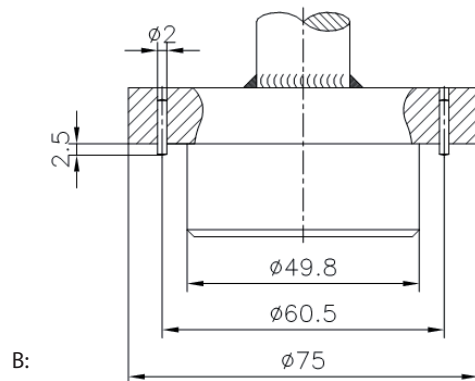
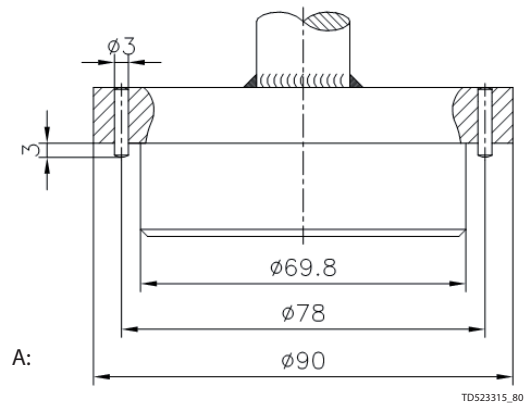

Alfa Laval IM 20 Rotary Jet Mixer
Part drawings, part lists, service kits & tools

Pos	Qty	Denomination	Item no.
Tools			
		Standard tool kit	TE81B075
Consisting of:			
	1	Hex key	TE134
	1	Hex screwdriver	TE134A
	1	Hex key	TE135
	1	Hex screwdriver	TE135A
	1	Open-end spanner	TE462

Pos	Qty	Denomination	Item no.
Available on request:			
		Pusher for Gear frame	TE81B031
		Fixture set f. Gear frame	TE81B032
		Tool for Upper collar (2" TCM) compl.	TE81B131
		Tool for Lower collar (2" TCM) compl.	TE81B132

Not manufactured anymore

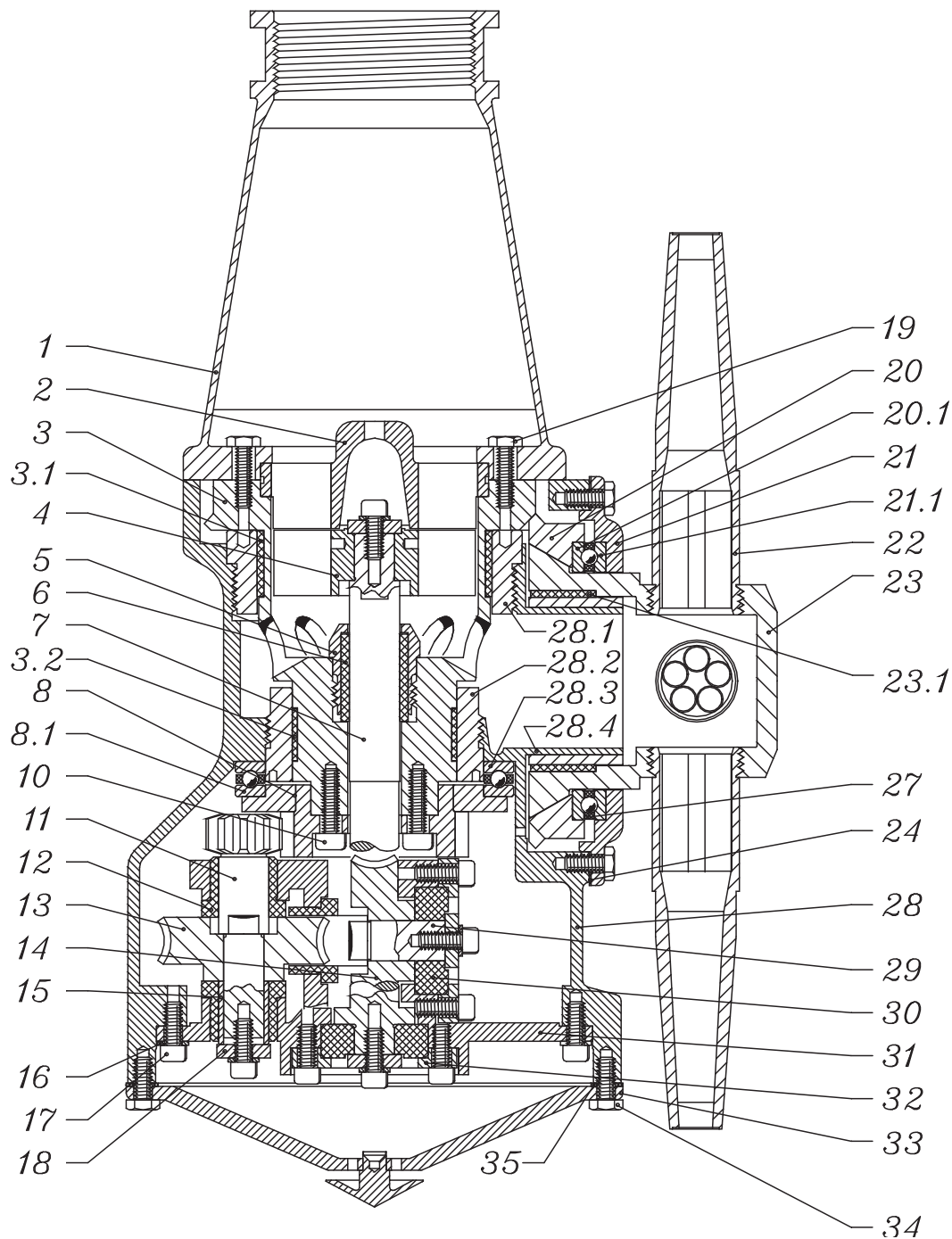

Pos	Qty	Denomination	Item no.	Material	Remark
Rotary Jet Mixer IM 20 with 4 nozzles					
Machine design obsolete December 29, 2010 - serial numbers below 1012-002					
1	<input type="checkbox"/>	1 Top cone, 2" BSP	TE22D500	Stainless steel	Spare part
	<input type="checkbox"/>	1 Top cone, 2" NPT	TE22D501	Stainless steel	Spare part
2	<input type="checkbox"/>	1 Guide, 100%	TE603	Stainless steel	Spare part
	<input type="checkbox"/>	1 Guide ring, 0%	TE1030	Stainless steel	Spare part
3		1 Stem w. liners	TE604Z	Stainless steel	Spare part
				/Polymer	
3.1		1 Top liner	TE9041 ²⁾	Polymer	Spare part
3.2		1 Bottom liner	TEB6042 ²⁾	Polymer	Spare part
4		1 Impeller, 100%	TE32B508	Stainless steel	Spare part
5		1 Gland	TE608Z	Stainless steel	Spare part
6	☉	1 Main bush	TE22B576	Polymer	Wear part
7	☉	1 Turbine shaft	TE32B511	Stainless steel	Wear part
8		1 Gear wheel w. ball race	TE32B303	Stainless steel	Spare part
8.1	☉	1 Ball race	TE32B510	Stainless steel	Wear part
10		6 Screw	TE120	Stainless steel	Spare part
11		1 Pinion	TE114	Stainless steel	Spare part
12	☉	3 Collar bush	TE22A586	Polymer	Wear part
13	☉	1 Worm wheel w. reinforcement	TE22A365	Polymer/Stain- less steel	Wear part
14	☉	1 Worm wheel w. reinforcement	TE22A365	Polymer/Stain- less steel	Wear part
15		1 Journal	TE117	Stainless steel	Spare part
16		9 Spring washer	TE156	Stainless steel	Spare part
17		17 Screw	TE118	Stainless steel	Spare part
18		4 Washer	TE619A	Stainless steel	Spare part
19		8 Screw	TE902H	Stainless steel	Spare part
20		1 Bevel gear with ball race	TE32B307	Stainless steel	Spare part
20.1	☉	1 Ball race	TE32B510	Stainless steel	Wear part
21		1 Hub cover with ball race	TE32B306	Stainless steel	Spare part
21.1	☉	1 Ball race	TE32B510	Stainless steel	Wear part
22	<input type="checkbox"/>	4 Nozzle, ø8	TE50B008	Stainless steel	Spare part
	<input type="checkbox"/>	4 Nozzle, ø9	TE50B009	Stainless steel	Spare part
	<input type="checkbox"/>	4 Nozzle, ø10	TE50B010	Stainless steel	Spare part
23		1 Hub w. liner	TE6244KZ	Stainless steel	Spare part
23.1		1 Hub liner	TE62411 ²⁾	Polymer	Wear part
24		1 Hub gasket	TE22D553	Polymer/elas- tomer	Spare part
27	☉	2 Ball retainer with balls	TE32B302	Polymer/ceram- ics	Wear part
28		1 Body with bearings ¹		Stainless steel	N/A
28.1		1 Main collar upper	TE127Z1	Stainless steel	Wear part
28.2		1 Main collar lower	TE127Z2	Stainless steel	Wear part
28.3	☉	1 Ball race	TE32B510	Stainless steel	Wear part
28.4		1 Hub collar	TE1273	Stainless steel	Wear part
29	☉	1 Horizontal shaft	TE128Z	Stainless steel	Wear part
30	☉	2 Slide bearing	TE22A571	Polymer	Wear part
31		1 Gear frame	TE630	Stainless steel	Spare part
32		2 Bearing cover	TE531	Stainless steel	Spare part
33		1 Bottom cover, compl.	TE22D350	Stainless steel	Spare part
34		12 Screw	TE421H	Stainless steel	Spare part
35		1 Bottom gasket	TE22D554	Polymer/elas- tomer	Spare part

Service kits

☉ **Service Kit - machines delivered before December 29, 2010 9614462201**

Parts marked with ☉ are included in the Service Kit 9614462201

¹⁾ Pos. 28 is not sold as single spare part component. Only sold as part of a machine maintenance/repair order. For further information please contact Alfa Laval Customer Support.

²⁾ If blue liners on Stem or blue liner on Hub are extremely worn, they can be replaced. This part requires that a precise procedure is followed to accomplish installation. It is highly recommended that an Authorized Alfa Laval Service Partner perform the replacement when necessary. Alternatively, it is possible to buy both Stem with liner and Hub with liner mounted.

Configuration according to delivery note/order.

How to contact Alfa Laval

Contact details for all countries are continually updated on our website.

Please visit www.alfalaval.com to access the information directly.

© Alfa Laval Corporate AB

This document and its contents is owned by Alfa Laval Corporate AB and protected by laws governing intellectual property and thereto related rights. It is the responsibility of the user of this document to comply with all applicable intellectual property laws. Without limiting any rights related to this document, no part of this document may be copied, reproduced or transmitted in any form or by any means (electronic, mechanical, photocopying, recording, or otherwise), or for any purpose, without the expressed permission of Alfa Laval Corporate AB. Alfa Laval Corporate AB will enforce its rights related to this document to the fullest extent of the law, including the seeking of criminal prosecution.