

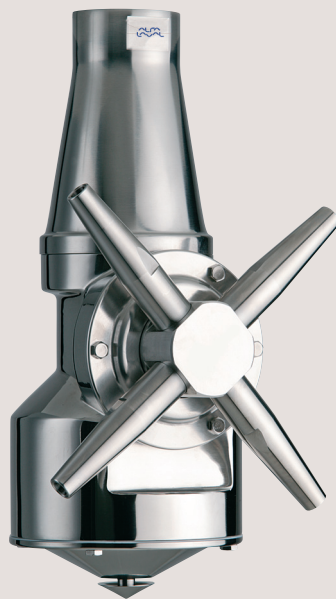

Spare Parts

Alfa Laval IM 15 Rotary Jet Mixer



EPS00206-EN7 2020-07

Original manual

The information herein is correct at the time of issue but may be subject to change without prior notice

1. Alfa Laval IM 15 Rotary Jet Mixer	
Part drawings, part lists, service kits & tools	4

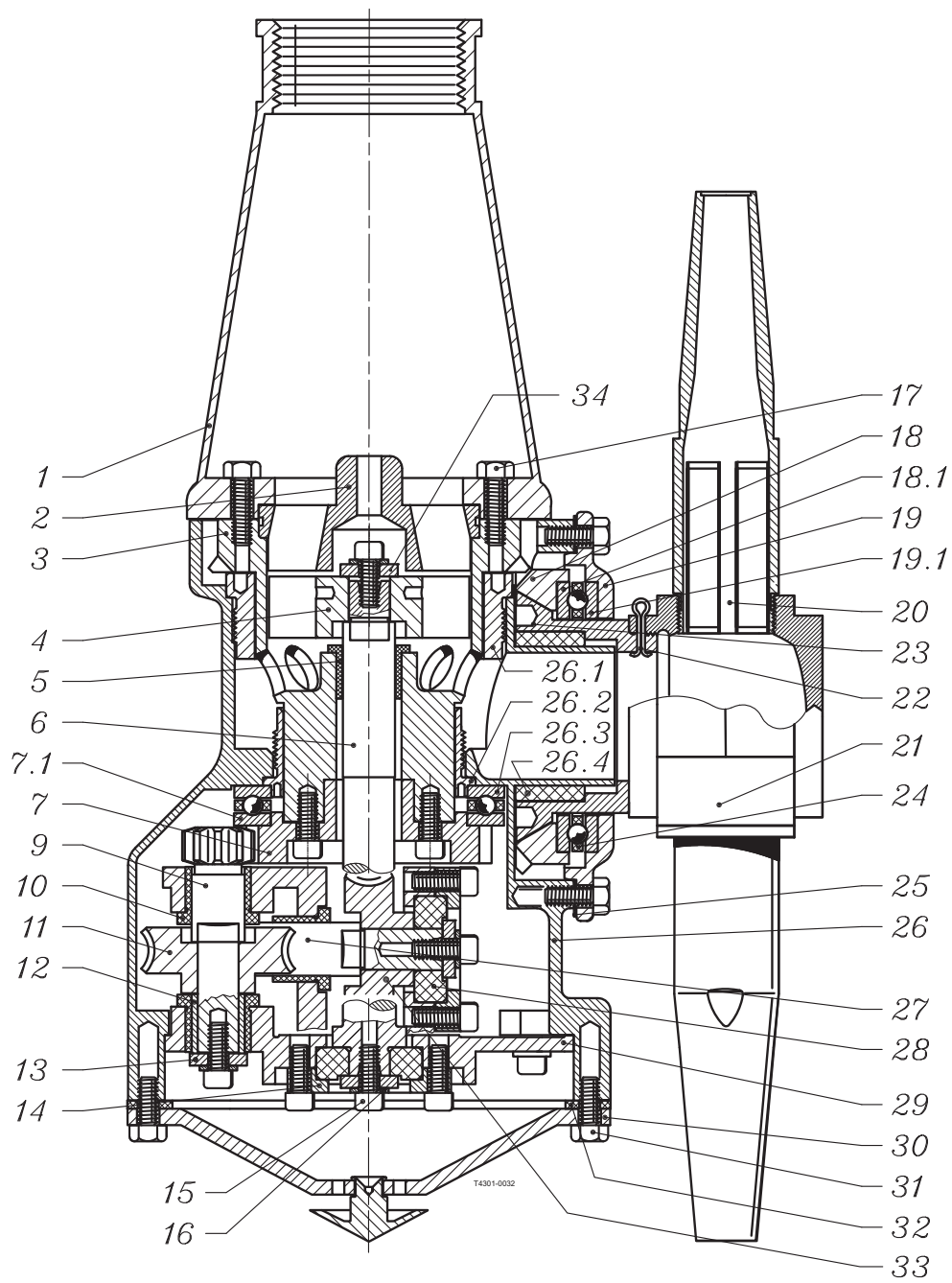

Alfa Laval IM 15 Rotary Jet Mixer
Part drawings, part lists, service kits & tools

Part List - Alfa Laval IM 15 Rotary Jet Mixer with 2 nozzles

Pos	Qty	Denomination	Item no.	Material	Material	Material	Remark
1	<input type="checkbox"/>	1 Top Cone, 1½" BSP	TE21D500	Stainless steel			Spare part
	<input type="checkbox"/>	1 Top Cone, 1½" NPT	TE21D501	Stainless steel			Spare part
2	<input type="checkbox"/>	1 Guide, 100%	TE703	Stainless steel			Spare part
	<input type="checkbox"/>	1 Guide ring, 0%	TE803-0	Stainless steel			Spare part
3	1	1 Stem	TE21B526	Stainless steel	Polymer		Spare part
4	1	1 Impeller, 100%	TE31B512	Stainless steel			Spare part
5	♦○	1 Main bush	TE21A526	Polymer			Wear part
6	♦○	1 Turbine shaft	TE31B511	Stainless steel			Wear part
7	1	1 Gear wheel w. ball race	TE31B304	Stainless steel			Spare part
7.1	♦○	(1) Ball race	TE31B510	Stainless steel			Wear part
9	1	1 Pinion	TE814	Stainless steel			Spare part
10	♦○	3 Collar bush	TE21A586	Polymer			Wear part
11	♦○	1 Worm wheel, w. reinforcement	TE21A367	Polymer			Wear part
12	1	1 Journal	TE817	Stainless steel			Spare part
13	3	3 Washer	TE719A	Stainless steel			Spare part
14	2	2 Bearing cover	TE731	Stainless steel			Spare part
15	22	22 Screw	TE118	Stainless steel			Spare part
16	8	8 Spring washer	TE156	Stainless steel			Spare part
17	6	6 Screw	TE402H	Stainless steel			Spare part
18	1	1 Bevel gear w. ball race	TE31B306	Stainless steel			Spare part
18.1	♦○	(1) Ball race	TE31B510	Stainless steel			Wear part
19	1	1 Hub cover w. ball race	TE31B305	Stainless steel			Spare part
19.1	♦○	(1) Ball race	TE31B510	Stainless steel			Wear part
20	<input type="checkbox"/>	2 Nozzle, ø8 mm	TE50B008	Stainless steel			Spare part
	<input type="checkbox"/>	2 Nozzle, ø9 mm	TE50B009	Stainless steel			Spare part
	<input type="checkbox"/>	2 Nozzle, ø10 mm	TE50B010	Stainless steel			Spare part
	<input type="checkbox"/>	2 Nozzle, ø11 mm	TE50B011	Stainless steel			Spare part
21	1	1 Hub	TE21B536	Stainless steel			Spare part
22	1	1 Split pin for 2 nozzle	TE448	Stainless steel			Spare part
23	1	1 Hub conical part	TE724215	Stainless steel			Spare part
24	<input type="checkbox"/>	2 Ball retainer with balls	TE31B303	Polymer	Ceramics		Wear part
	<input type="checkbox"/>	2 Ball retainer with balls	TE21A380	Polymer	Stainless steel		Wear part
25	1	1 Hub gasket	TE21D562	Polymer	Elastomer		Spare part
26	1	1 Body, 1)		Stainless steel			
26.1	1	1 Main collar upper	TE21B520	Polymer			Wear part
26.2	1	1 Main collar lower	TE21B521	Polymer			Wear part
26.3	♦○	(1) Ball race	TE31B510	Stainless steel			Wear part
26.4	1	1 Hub collar	TE21D522	Polymer			Wear part
27	♦○	1 Horizontal shaft	TE828Z	Stainless steel			Wear part
28	♦○	2 Slide bearing	TE21A571	Polymer			Wear part
29	1	1 Gear frame	TE730	Stainless steel			Spare part
30	1	1 Bottom cover compl.	TE21D350	Stainless steel			Spare part
31	10	10 Hex Screw	TE421H	Stainless steel			Spare part
32	1	1 Bottom gasket	TE21D563	Elastomer	Polymer		Spare part
33	♦○	1 Worm wheel w. reinforcement	TE21A367	Polymer			Wear part
34	1	1 Washer	TE31B515	Stainless steel			Spare part

Item no.

Service kits

- ♦ **Standard service kit** **TE31B299**
- **Standard service kit for ATEX/IECEx machines** **TE31B29970**

1) Pos. 26 is not sold as single spare part component. Only sold as part of a machine maintenance/repair order. For further information please contact Alfa Laval Customer Support.

Please note that some of the polymer parts are in PEEK. PEEK is not resistant to concentrated sulfuric acid.

Configuration according to delivery note/order.

Parts marked with ♦ are included in the Standard Service Kit TE31B299

Parts marked with ○ are included in the Standard Service Kit TE31B29970 (ATEX/IECEx)

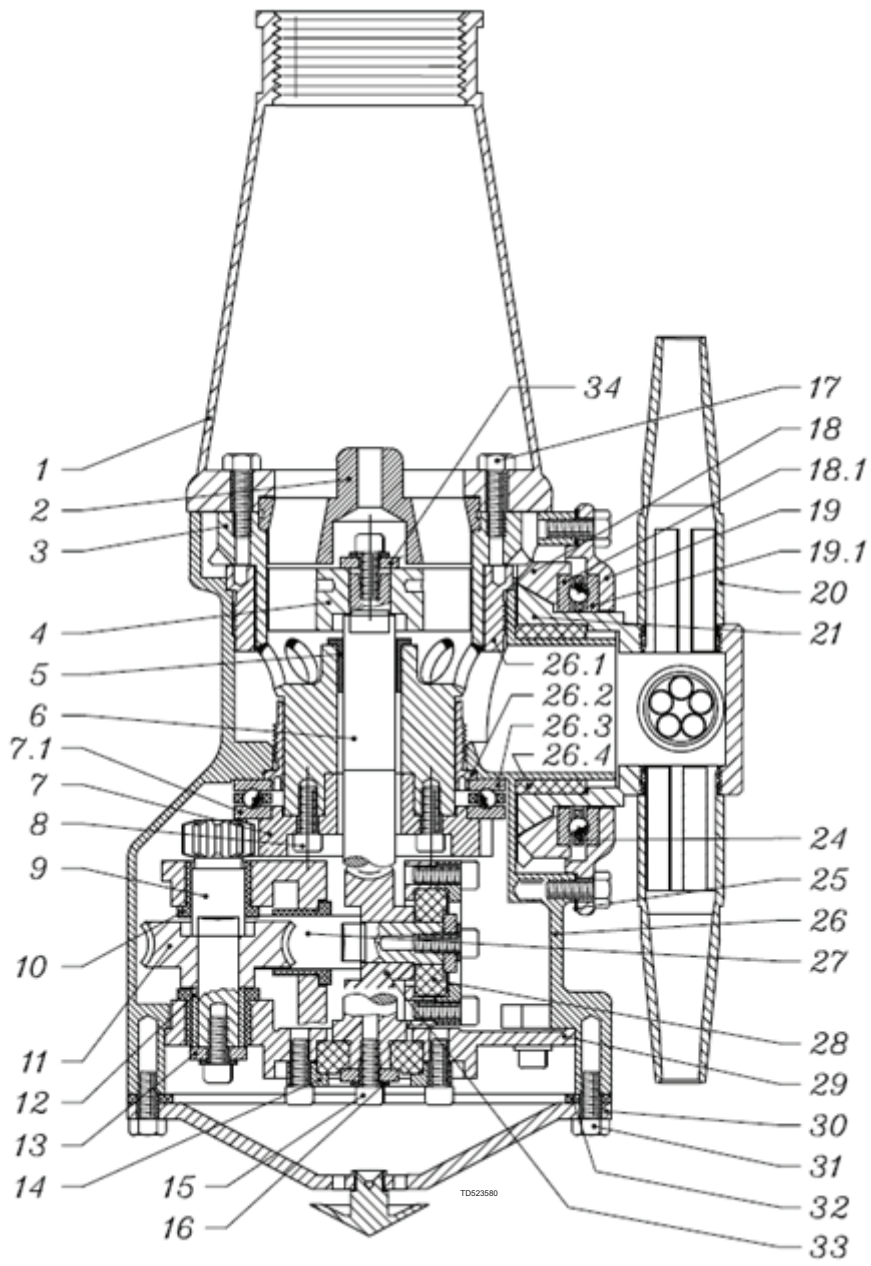

Alfa Laval IM 15 Rotary Jet Mixer
Part drawings, part lists, service kits & tools

Part List - Alfa Laval IM 15 Rotary Jet Mixer with 4 nozzles

Pos	Qty	Denomination	Item no.	Material	Material	Remark
1	<input type="checkbox"/>	1 Top Cone , 1½" BSP	TE21D500	Stainless steel		Spare part
	<input type="checkbox"/>	1 Top Cone , 1½" NPT	TE21D501	Stainless steel		Spare part
2	<input type="checkbox"/>	1 Guide , 100%	TE703	Stainless steel		Spare part
	<input type="checkbox"/>	1 Guide, 0%	TE803-0	Stainless steel		Spare part
3		1 Stem	TE21B526	Stainless steel		Spare part
4		1 Impeller, 100%	TE31B512	Stainless steel		Spare part
5	◆○	1 Main bush	TE21A526	Polymer		Wear part
6	◆○	1 Turbine shaft	TE31B511	Stainless steel		Wear part
7		1 Gear wheel w. ball race	TE31B304	Stainless steel		Spare part
7.1	◆○	1 Ball race	TE31B510	Stainless steel		Wear part
9		1 Pinion	TE814	Stainless steel		Spare part
10	◆○	3 Collar bush	TE21A586	Polymer		Wear part
11	◆○	1 Worm wheel, w. reinforcement	TE21A367	Polymer		Wear part
12		1 Journal	TE817	Stainless steel		Spare part
13		3 Washer	TE719A	Stainless steel		Spare part
14		2 Bearing cover	TE731	Stainless steel		Spare part
15	22	Screw	TE118	Stainless steel		Spare part
16	8	Spring washer	TE156	Stainless steel		Spare part
17	6	Screw	TE402H	Stainless steel		Spare part
18	1	Bevel gear w. ball race	TE31B306	Stainless steel		Spare part
18.1	◆○	1 Ball race	TE31B510	Stainless steel		Wear part
19	1	Hub cover w. ball race	TE31B305	Stainless steel		Spare part
19.1	◆○	1 Ball race	TE31B510	Stainless steel		Wear part
20	<input type="checkbox"/>	4 Nozzle , ø6 mm	TE50A006	Stainless steel		Spare part
	<input type="checkbox"/>	4 Nozzle, ø7 mm	TE50A007	Stainless steel		Spare part
	<input type="checkbox"/>	4 Nozzle, ø8 mm	TE50A008	Stainless steel		Spare part
21		1 Hub for 4 nozzle	TE21C536	Stainless steel		Spare part
24	<input type="checkbox"/> ◆	2 Ball retainer with balls	TE31B303	Polymer	Ceramics	Wear part
	<input type="checkbox"/> ○	2 Ball retainer with balls	TE21A380	Polymer	Stainless steel	Wear part
25		1 Hub gasket	TE21D562	Polymer	Elastomer	Spare part
26		1 Body, ¹⁾		Stainless steel		
26.1		1 Main collar upper	TE21B520	Polymer		Wear part
26.2		1 Main collar lower	TE21B521	Polymer		Wear part
26.3	◆○	1 Ball race	TE31B510	Stainless steel		Wear part
26.4		1 Hub collar	TE21D522	Polymer		Wear part
27	◆○	1 Horizontal shaft	TE828Z	Stainless steel		Wear part
28	◆○	2 Slide bearing	TE21A571	Polymer		Wear part
29		1 Gear frame	TE730	Stainless steel		Spare part
30		1 Bottom cover compl.	TE21D350	Stainless steel		Spare part
31	10	Hex Screw	TE421H	Stainless steel		Spare part
32		1 Bottom gasket	TE21D563	Elastomer	Polymer	Spare part
33	◆○	1 Worm wheel w. reinforcement	TE21A367	Polymer		Wear part
34		1 Washer	TE31B515	Stainless steel		Spare part

Item no.

Service kits

Standard Service Kit	TE31B299
Standard service kit for ATEX/IECEx machines	TE31B29970

¹⁾ Pos. 26 is not sold as single spare part component. Only sold as part of a machine maintenance/repair order. For further information please contact Alfa Laval Customer Support.

Please note that some of the polymer parts are in PEEK. PEEK is not resistant to concentrated sulfuric acid.

Configuration according to delivery note/order.

Parts marked with ◆ are included in the Standard Service Kit TE31B299

Parts marked with ○ are included in the Standard Service Kit TE31B29970 (ATEX/IECEx)

Service intervals

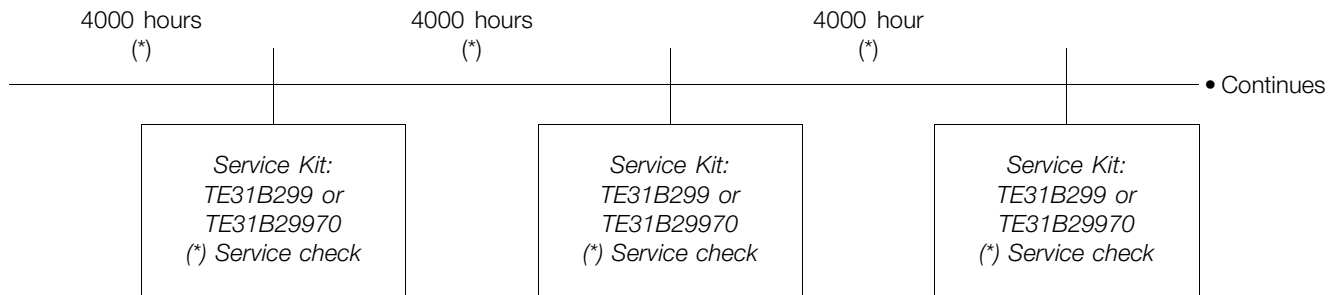

NOTE

The service intervals are recommended on the basis of pure liquids. When liquids contain particles and other kind of abrasives, we recommend shorter service intervals depending on the actual running conditions.

Alfa Laval IM 15 Rotary Jet Mixer
Part drawings, part lists, service kits & tools

Pos	Qty	Denomination	Item no.
Service kits			
		Service kit for IM 15	TE31B299
Consisting of:			
-	2	Worm wheel w. steel core	TE21A367
-	1	Main bush	TE21A526
	2	Slide bearing	TE21A571
	3	Collar Bush	TE21A586
	2	Ball Retainer with Balls	TE31B303
	4	Ball Race	TE31B510
	1	Turbine Shaft	TE31B511
	1	Horizontal Shaft	TE828Z

Pos	Qty	Denomination	Item no.
		Service Kit for IM 15 ATEX/IECEx	TE31B29970
Consisting of:			
-	2	Worm wheel w. steel core	TE21A367
-	1	Main bush	TE21A526
	2	Slide bearing	TE21A571
	3	Collar Bush	TE21A586
	2	Ball retainer with balls	TE21a380
	4	Ball Race	TE31B510
	1	Turbine Shaft	TE31B511
	1	Horizontal Shaft	TE828Z

Tools for replacement of Collars bush

TE81B033: Pusher for 1½" Collar bush

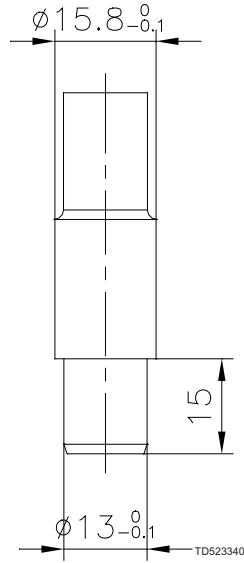

Sketch of tools for replacement of Main collars

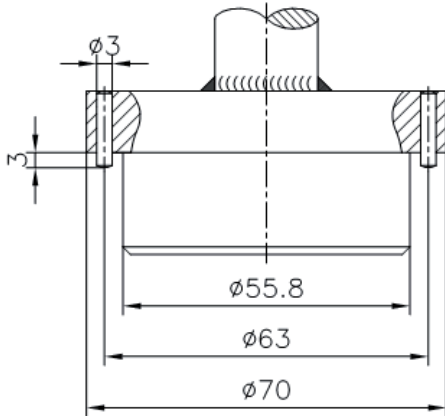

TE81B129: Tool for upper collar

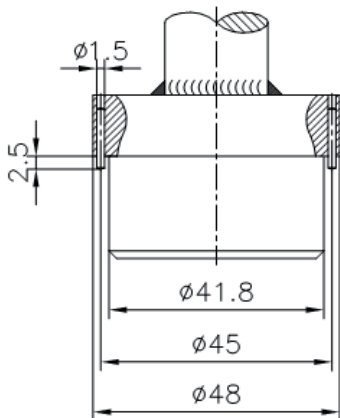

TE81B130: Tool for lower collar

Alfa Laval IM 15 Rotary Jet Mixer
Part drawings, part lists, service kits & tools

Pos	Qty	Denomination	Item no.
-----	-----	--------------	----------

Standard tool kit

		Standard tool kit	TE81B055
Consisting of:			
	1	Hex key	TE134
	2	Hex screwdriver	TE134A
	1	Socket wrench w. pin	TE462A

Available on request:

Pos	Qty	Denomination	Item no
	1	Pusher f. 1½" machines	TE81B033
	1	Tool f. upper collar (1½" TCM) compl.	TE81B129
-		Tool f. lower collar (1½" TCM) compl.	TE81B130

How to contact Alfa Laval

Contact details for all countries are continually updated on our website.

Please visit www.alfalaval.com to access the information directly.

© Alfa Laval Corporate AB

This document and its contents is owned by Alfa Laval Corporate AB and protected by laws governing intellectual property and thereto related rights. It is the responsibility of the user of this document to comply with all applicable intellectual property laws. Without limiting any rights related to this document, no part of this document may be copied, reproduced or transmitted in any form or by any means (electronic, mechanical, photocopying, recording, or otherwise), or for any purpose, without the expressed permission of Alfa Laval Corporate AB. Alfa Laval Corporate AB will enforce its rights related to this document to the fullest extent of the law, including the seeking of criminal prosecution.