

Alfa Laval EnSaLine S and EnSaLine B

Agitators



Lit. Code

200019887-1-EN-GB

Instruction manual

Published by
Alfa Laval Kolding A/S
Albuen 31
DK-6000 Kolding, Denmark
+45 79 32 22 00

The original instructions are in English

© Alfa Laval AB 2026-03

This document and its contents are subject to copyrights and other intellectual property rights owned by Alfa Laval AB (publ) or any of its affiliates (jointly "Alfa Laval"). No part of this document may be copied, re-produced or transmitted in any form or by any means, or for any purpose, without Alfa Laval's prior express written permission. Information and services provided in this document are made as a benefit and service to the user, and no representations or warranties are made about the accuracy or suitability of this information and these services for any purpose. All rights are reserved.

Contents

1	Declarations of Conformity	5
1.1	EU Declaration of Conformity.....	5
1.2	UK Declaration of Conformity.....	6
2	Safety	7
2.1	Safety signs.....	8
2.2	Safety precautions.....	9
2.3	Warning signs in text.....	12
2.4	Requirements of Personnel.....	13
2.5	Recycling Information.....	14
3	Introduction	15
3.1	Intended use.....	15
4	Installation	17
4.1	Unpacking/delivery.....	17
4.2	General installation.....	20
4.3	Welding flange.....	20
4.4	Mounting agitator.....	22
4.5	Pre-use check.....	29
5	Operation	33
5.1	General operation.....	33
5.2	Operation/control.....	33
5.3	Troubleshooting.....	35
5.4	Cleaning recommendations.....	37
5.5	Temperature limits.....	37
5.6	Pressure limits.....	38
6	Maintenance	39
6.1	General maintenance.....	39
6.1.1	Preventive maintenance.....	40
6.2	Replacement of seal cartridge and top bearing.....	41
6.3	Replacement of seal faces and lower bearing.....	61
7	Technical Data	75
7.1	General technical data.....	75
7.2	Connecting flush – seal type CD.....	76
7.3	Tightening torques for bolt connections.....	78
7.4	Spider coupling.....	78
7.5	Storage.....	79

8	Spare Parts	81
8.1	Ordering Spare Parts.....	81
8.2	Alfa Laval Service.....	81
8.3	Warranty - definition.....	82
9	Parts Lists and Exploded Views	83
9.1	Agitator overview.....	83
9.2	Drive unit.....	84
9.3	Drive train.....	85
9.4	Top bearing assembly size A45.....	86
9.5	Top bearing assembly, size A30.....	87
9.6	Cartridge Double seal (CD), size A45.....	88
9.7	Cartridge Wet Seal (CWS), size A45.....	89
9.8	Cartridge Double seal (CD), size A30.....	90
9.9	Cartridge Wet Seal (CWS), size A30.....	91
9.10	Hinge jack.....	92
9.11	Center jack.....	93
9.12	Shaft retainer.....	94
10	Appendix	95
10.1	Drive unit instructions.....	95

1 Declarations of Conformity

1.1 EU Declaration of Conformity

The designated company

Alfa Laval Kolding A/S, Albuen 31, DK-6000 Kolding, Denmark, +45 79 32 22 00

Company name, address and phone number

Hereby declare that

Agitator – EnSaLine

Designation

B-A30-H, B-A30-H3, B-A30-UP, B-A30-UP3, B-A30-I, S-A30-H, S-A30-H3, S-A30-UP, S-A30-UP3, S-A30-I,
B-A45-H, B-A45-H3, B-A45-UP, B-A45-UP3, B-A45-I, S-A45-H, S-A45-H3, S-A45-UP, S-A45-UP3, S-A45-I

Type

AAC000000001 to AAC999999999

Serial number

is in conformity with the following directives with amendments:

- Machinery Directive 2006/42/EC
- RoHS Directive 2011/65/EU and amendments

The person authorised to compile the technical file is the signer of this document.

Vice President BU Hygienic Fluid Handling

Head of Product Management

Title

Mikkel Nordkvist

Name

Kolding, Denmark

Place

2026-03-01

Date (YYYY-MM-DD)



Signature

DoC Revison_ 01_032026



1.2 UK Declaration of Conformity

The designated company

Alfa Laval Kolding A/S, Albuen 31, DK-6000 Kolding, Denmark, +45 79 32 22 00

Company name, address and phone number

Hereby declare that

Agitator – EnSaLine

Designation

B-A30-H, B-A30-H3, B-A30-UP, B-A30-UP3, B-A30-I, S-A30-H, S-A30-H3, S-A30-UP, S-A30-UP3, S-A30-I,
B-A45-H, B-A45-H3, B-A45-UP, B-A45-UP3, B-A45-I, S-A45-H, S-A45-H3, S-A45-UP, S-A45-UP3, S-A45-I

Type

AAC000000001 to AAC999999999

Serial number

is in conformity with the following directives with amendments:

- The Supply of Machinery (Safety) Regulations 2008
- The Restriction of the Use of Certain Hazardous Substances in Electrical and Electronic Equipment Regulations 2012

Signed on behalf of: Alfa Laval Kolding A/S.

Vice President BU Hygienic Fluid Handling

Head of Product Management

Title

Mikkel Nordkvist

Name

Kolding, Denmark

Place

2026-03-01

Date (YYYY-MM-DD)



Signature

DoC Revisor_ 01_032026



2 Safety

Read this first



Unsafe practices and other important information are emphasised in this Instruction manual.

Warnings are emphasised by means of special signs.

Always read the Instruction manual before using the agitator!

This Instruction manual is the primary document for safety, installation, operation and maintenance of Alfa Laval EnSaLine S and EnSaLine B.

This document does not contain the welding guide for the welding flange.

For this information read the "Alfa Laval EnSaLine Welding Guidelines" available on www.alfalaval.com.

This Instruction manual is designed to provide the user with the information to perform tasks safely for all phases in the lifetime of the product supplied.

The user shall always read the safety section first. Hereafter the user can skip to the relevant section for the task to be carried out or for the information needed.

This is the complete Instruction manual for the supplied Alfa Laval product.



NOTE

The illustrations and specifications in this Instruction manual were effective at the date of printing. However, as continuous improvements are our policy, we reserve the right to alter or modify the Instruction manual without prior notice or any obligation.





The English version of the Instruction manual is the original manual. Alfa Laval cannot be held responsible for incorrect translations. In case of doubt, the English version applies.

2.1 Safety signs

Mandatory action signs

	General mandatory action sign.
	Refer to instruction manual.
	Use ear protection in noisy environments - noise protector.

Warning signs

	General warning.
	Electricity.
	Corrosive substance.
	Heavy object lifting.
	Transportation with forklift truck or other industrial vehicles if heavy.

2.2 Safety precautions

NOTE

Unsafe practices and other important information are emphasised in this Instruction manual.

Warnings are emphasised by means of special signs.

All warnings in the Instruction manual are summarised on these pages.



Always read the Instruction manual before using the agitator.

Illustrations are only to illustrate the problem and is NOT a drawing of the current agitator.





WARNING



Pay special attention to the instructions below so that severe personal injury and/or damage to the agitator are avoided.

General







 	<p>Always ensure that personnel must have experience with lifting operations.</p>
	<p>Always ensure the lifting point to be in line with center of gravity. Adjust lifting point if necessary.</p>
	<p>Always keep an eye on the load and stay clear during the lifting operation.</p>
	<p>Always ensure that the lifting equipment is suitable for the specific supplied product.</p>
	<p>Always use appropriate lifting equipment for heavy parts when relevant. Use lifting logs when available.</p>

Installation

 	<p>Always read <i>Technical Data</i> on page 75 thoroughly.</p> <p>Always follow installation instructions thoroughly (see <i>Installation</i> on page 17).</p>
	<p>Never expose the agitator to undue vibrations or shocks.</p>
	<p>Never start the agitator in the wrong rotation direction.</p>
	<p>Ensure that the tank media is not corrosive to the agitator.</p>

	<p>Only install the agitator in environments within temperature limit: -20°C and +40°C.</p> <p>Only install the agitator in altitudes less than 1000 m above sea level.</p>
	<p>Never touch the moving parts while the agitator is connected to the power supply.</p>

Operation

 	<p>Always read <i>Technical Data</i> on page 75 thoroughly.</p>
	<p>Never start the agitator in the wrong rotation direction.</p>
	<p>Always rinse well with clean water after cleaning.</p>
	<p>Beware of temperature limitations.</p>
	<p>Never operate continuously within 20% of critical oscillation speed (see <i>Technical Data</i> on page 75).</p>
	<p>Never touch the moving parts while the agitator is connected to the power supply.</p>

Maintenance

	<p>Always read <i>Technical Data</i> on page 75 thoroughly.</p> <p>Always follow the maintenance instruction thoroughly (see <i>Maintenance</i> on page 39).</p>
	<p>Always follow the maintenance instruction from drive unit supplier (see <i>Appendix</i> on page 95).</p> <p>Always study the parts list and assembly drawing carefully (see <i>Parts Lists and Exploded Views</i> on page 83).</p>
	<p>Never touch the moving parts while the agitator is connected to the power supply.</p> <p>Always disconnect the power supply while servicing the agitator.</p>
	<p>Ensure correct rotation direction of impeller before startup and after any maintenance which might have impact on the direction.</p>

Transportation

	<p>Always transport the agitator in original packaging.</p> <p>Always support the shaft adequately, to protect shaft and bearings.</p> <p>Never expose the agitator to undue vibrations or shocks.</p> <p>Control for oil leakage on gears with vent screw.</p>
--	--

Storage

	<p>Store the agitator in dry and clean environments.</p> <p>Rotate shaft every second week to ensure seal faces do not stick together.</p>
 	<p>Alfa Laval recommends:</p> <ul style="list-style-type: none"> • Store the supplied Alfa Laval product as supplied in original packaging • Port opening(s) should be protected against ingress • Bare steel (not stainless) should be lightly oiled/greased • Store in a clean, dry place without direct sunlight or UV light • Temperature range -5° C to +40° C (23° F - 104° F) • Relative humidity less than 60% • No exposure to corrosive substances (including contained air) • Rinse supplied Alfa Laval product with clean water before storage

Noise

	<p>Beware of agitator in operation can produce sound levels in excess of 85dB(A).</p>
--	---

2.3 Warning signs in text

Pay attention to the safety instructions in this Instruction manual.

Below are definitions of the three grades of warning signs used in the text where there is a risk for injury to personnel or damage to the supplied Alfa Laval product.

 **WARNING**

Indicates a potentially hazardous situation which, if not avoided, could result in death or serious injury.

 **CAUTION**

Indicates a potentially hazardous situation which, if not avoided, may result in minor or moderate damage to the supplied Alfa Laval product.

 **NOTE**

Indicates important information to simplify or clarify procedures.

2.4 Requirements of Personnel

Operators

The operators shall read and understand this Instruction Manual.

Maintenance personnel

The maintenance personnel shall read and understand this Instruction Manual. The maintenance personnel or technicians shall be skilled within the field required to carry out the maintenance work safely.

Trainees

Trainees can perform tasks under the supervision of an experienced employee.

People in general

The public shall not have access to the supplied Alfa Laval product.

In some cases, specially skilled personnel may need to be hired (i.e. electricians, welders). In some cases the personnel has to be certified according to local regulations with experience of similar types of work.

2.5 Recycling Information

Unpacking

Packing material may consist of wood, plastics, cardboard boxes and in some cases metal straps.



- Wood and cardboard boxes can be reused, recycled or used for energy recovery
- Plastics should be recycled or burnt at a licensed waste incineration plant
- Metal straps should be sent for material recycling

Maintenance

During maintenance, oil (if used) and wear parts in the supplied Alfa Laval product should be replaced.

- Oil and all non-metal wear parts must be disposed of in accordance with local regulations
- Rubber and plastics should be burnt at a licensed waste incineration plant. If not available they should be disposed of in accordance with local regulations
- Bearings and other metal parts should be sent to a licensed handler for material recycling
- Seal rings and friction linings should be disposed of to a licensed land fill site. Check your local regulations
- All metal parts should be sent for material recycling
- Worn out or defected electronic parts should be sent to a licensed handler for material recycling

Scrapping

At end of use, the equipment must be recycled in accordance with the relevant local regulations. Besides the equipment itself, any hazardous residues from the process liquid must be considered and dealt with in a proper manner. When in doubt, or in the absence of local regulations, please contact your local Alfa Laval sales company.

How to contact Alfa Laval

Contact details for all countries are continually updated on our website.

Please visit www.alfalaval.com to access the information directly.

3 Introduction

Alfa Laval EnSaLine is bottom-mounted and side-mounted agitators for hygienic mixing and agitation in atmospheric and pressurized tanks, raising the bar for agitator performance. Designed for exceptional energy efficiency, easy maintenance and gentle product treatment, EnSaLine maximizes yield and delivers immediate savings in time and operating costs. Exceptional cleanability makes the EnSaLine agitator ideal for use in sterile and aseptic applications. EnSaLine is prepared for wireless condition monitoring.

3.1 Intended use

- The Alfa Laval agitator is only for mixing/stirring of liquids in a tank
- The agitator is only for mounting positions as specified on the nameplate by the first group of letters of the type designation

0-89° is for bottom mounting, 90-150° is for side mounting and 151-180° is for top mounting.

The exact mounting angle range is specified on the nameplate and must be followed. Definitions on mounting angles can be seen in section [Mounting agitator](#) on page 22.

- The different duties and operation data like pressure, speed and media temperature, which the agitator is designed for, can be found in the Alfa Laval quotation agreement¹ and may not be exceeded by all means
- If the agitator is installed in pressurized tanks local regulations and legislations must be met

¹ The Alfa Laval quotation agreement has been exchanged during the quote process between a technical purchaser and Alfa Laval. If you are not in hold of the Alfa Laval quotation agreement, please get through to your local Alfa Laval contact, inform the agitator serial number and article number which is stated on the Name Plate and you will obtain the Alfa Laval quotation agreement.

This page is intentionally left blank.

4 Installation

4.1 Unpacking/delivery

WARNING

Always use lifting equipment when handling the agitator, see lifting instructions below.

CAUTION

Alfa Laval cannot be held responsible for incorrect unpacking.



NOTE

The Instruction manual is part of the delivery.
Study the instructions carefully.

Inspect the delivery for visible transportation damages - all issues to be reported to carrier.

Check the delivery for:

1. Complete agitator
2. Nameplate designations
3. Delivery note
4. Separate instruction manuals from suppliers (see [Appendix](#) on page 95)

Designation		Certificate
Agitator - EnSaLine		
Manufacturer		
Alfa Laval Kolding A/S		
Albuen 31, 6000-DK		
Type	Serial no.	This mixing device is designed for steam sterilisation and mechanical cleaning
A30	xxxxxxxxxx	
Article no.	Mounting angle	
xxxxxxxxxx	xxx-xxx deg	
Year	Weight Kg	Rotation direction
20xx	xxxx	
Service enquiries www.alfalaval.com		

4311-0002

Lifting instructions:

WARNING

Always use the correct lifting equipment (see agitator weight on name plate).

The agitator is delivered in a closed pallet box where the agitator is divided into 5 main components which should be handled separately.

1. Drive unit (with shroud base if specified)
2. Drive train with shaft
3. Impeller
4. Shroud (if specified)
5. Welding flange (shipped separately)

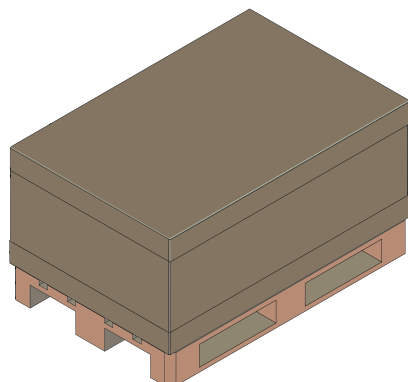

4311-0007

Drive unit:

To handle the drive unit, attach a lifting strap around the gear unit between the motor and the gearbox.

WARNING

Always use adequate lifting equipment with a working load limit (WLL) of minimum 250 kg/551 lbs.

Do **NOT** use eye bolt on gear unit to lift the agitator. They are only for gear unit removal.

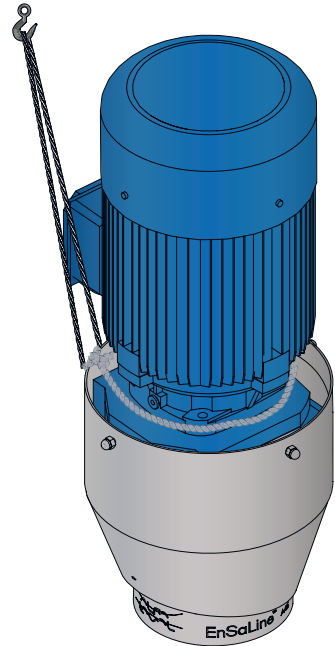
**Drive train with shaft:**

To handle the drive train, attach two M10 lifting nuts (1) to the drive train top flange. Attach one lifting strap to the eye nuts and another around the shaft.

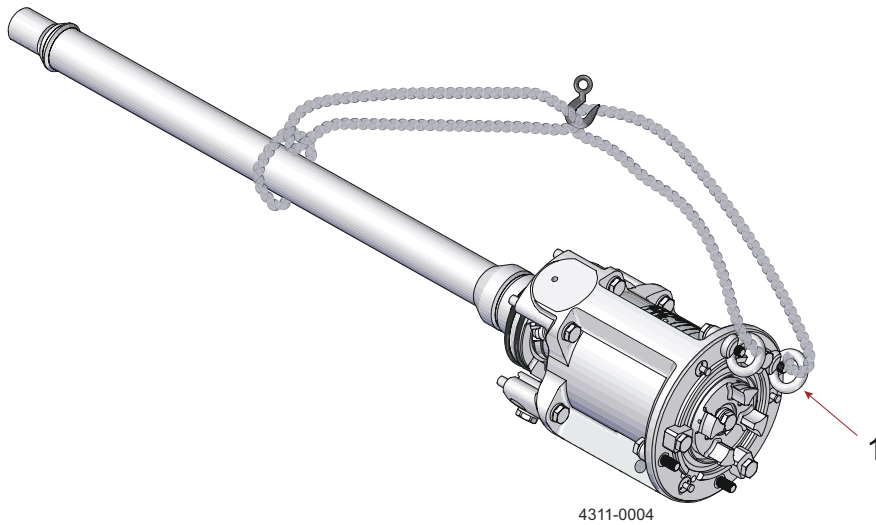
**WARNING**

Always use adequate lifting equipment with a working load limit (WLL) of minimum 250 kg/551 lbs.

Impeller:

To handle the impeller, ensure that the lifting straps are firmly secured to two blades of the impeller.

NOTE

If manual handling is not possible, use lifting straps. Secure the straps firmly around two impeller blades to ensure a safe lift.



Shroud:

The shroud is handled by hand and comes in two sizes.

Size (mm/inch)				
	a	b	c	Weight (kg/lbs)
Small	412/16.22	286/11.26	111/4.37	4/8.8
Medium	522/20.55	372/14.65	152/5.98	7/15.4

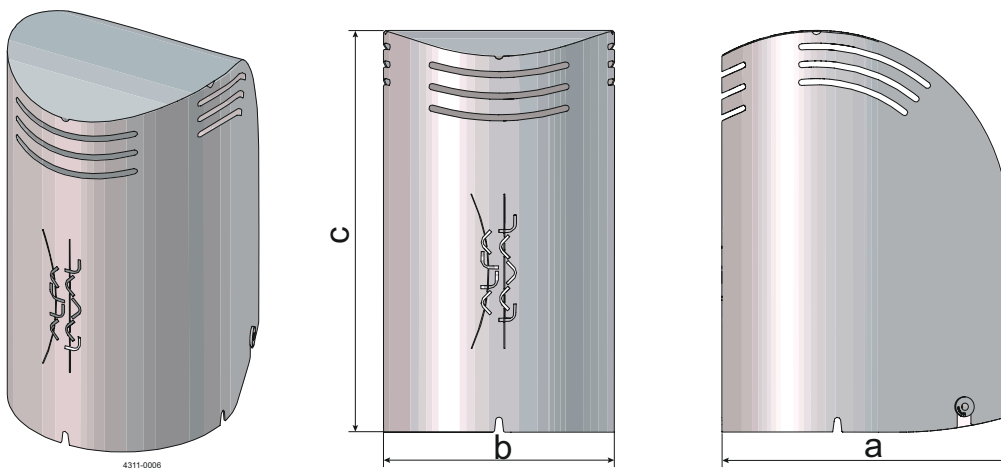

During transportation:



WARNING

Always support the shaft adequately to protect shaft and bearings.

Never expose the agitator to undue vibrations or shocks.

Control for oil leakage on gears with vent screw.

4.2 General installation



WARNING

Always read the *Technical Data* on page 75 thoroughly.

Always use lifting equipment when handling the agitator.

Always use lifting equipment when handling the agitator (see *Unpacking/delivery* on page 17).

Always have safety elements removed by authorized personnel.

Never cover or remove the nameplate.



WARNING

Never connect to power supply during installation or service.

Always have the agitator connected to power supply by authorized personnel.



NOTE

Study the instructions carefully and pay special attention to the warnings!

Always check the agitator before operation - see *Pre-use check* on page 29.

Always check the agitator before operation.

The agitator is for permanent fastening.

Make sure that the motor corresponds to the environment.



NOTE

Alfa Laval highly recommends to install motor protection guard to protect the motor from overloading.

Never install a non-Alfa Laval shroud on the agitator as it can lead to overheating and a breakdown of the motor.

4.3 Welding flange

Follow the guide in "Alfa Laval EnSaLine Welding Guidelines" for welding of the welding flange into the tank available on [www.alfalaval.com](https://www.alfalaval.com/products/fluid-handling/mixing-equipment/agitators/ensaline/): <https://www.alfalaval.com/products/fluid-handling/mixing-equipment/agitators/ensaline/>



Only use authorized personnel to weld in the welding flange.
Alfa Laval cannot be held responsible for incorrect installation.

- 2 Lift the drive train with shaft up and through the welding flange with the lifting strap as illustrated.

For the bottom mounted agitator it is recommended to use a threaded cup that matches the thread on the shaft end to attach the lifting strap. The thread comes in two sizes of left-handed thread M20L and M36L.

 CAUTION

Be careful not to damage the seal (2) when inserting it into the welding flange.

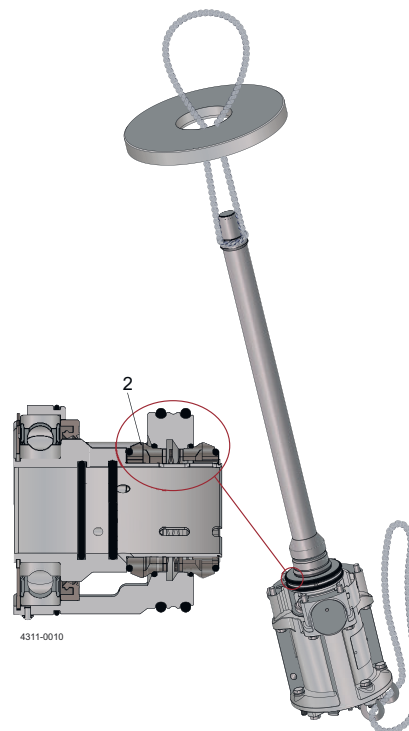
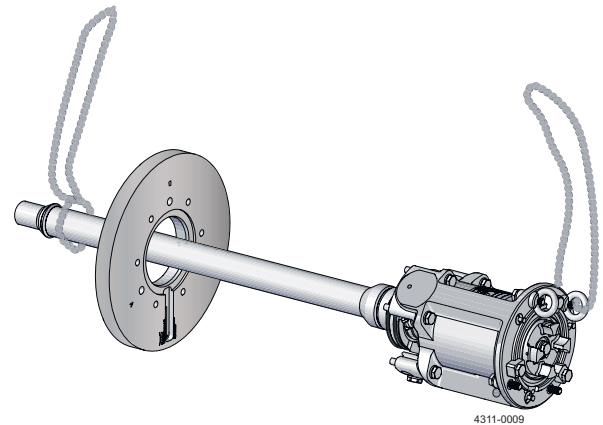
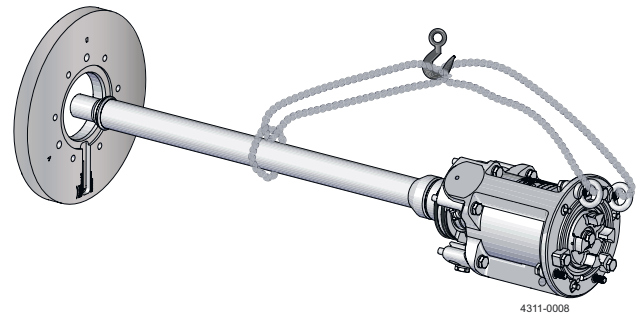

- 3** Fully insert the component into the welding flange, then tighten the eight bolts (3) to 51 Nm/37.62 ft-lb.

Unscrew the two lifting eye nuts (4).

Ensure that the hinge jack attachment point (5) is in the direction of the drain.

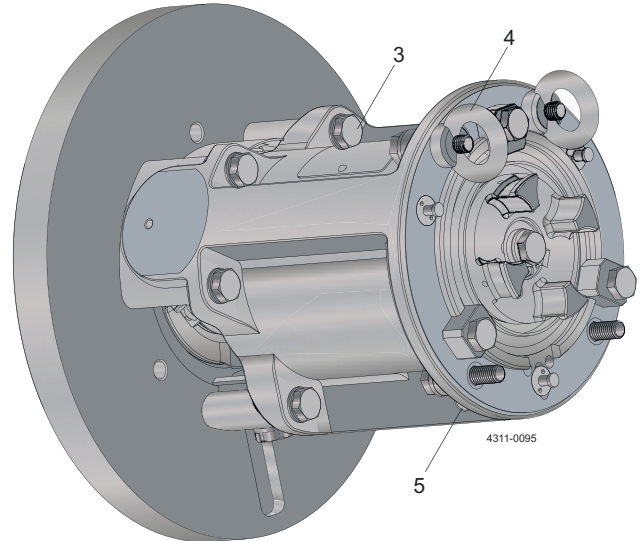

- 4** Attach the spider (7) to the coupling.

Attach the O-ring (8) and the seal cover plates (9) to the housing.

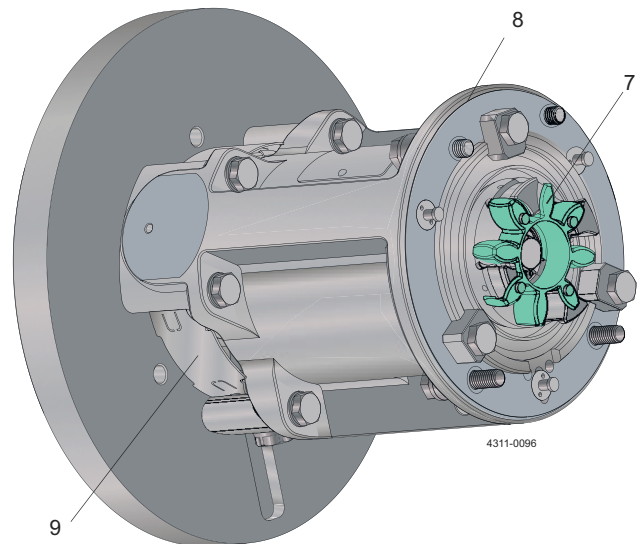

- 5 Attach the drive unit to the drive train, then tighten the fire bolts (10) to 51 Nm//37.62 ft-lb.

For gears with vent screw, ensure to remove the rubber plug (12).

CAUTION

Align the claws of the two coupling parts so they merge easily.

Use a 3 mm/0.19 inch Allen key and the hole (11) in the coupling for easy alignment.

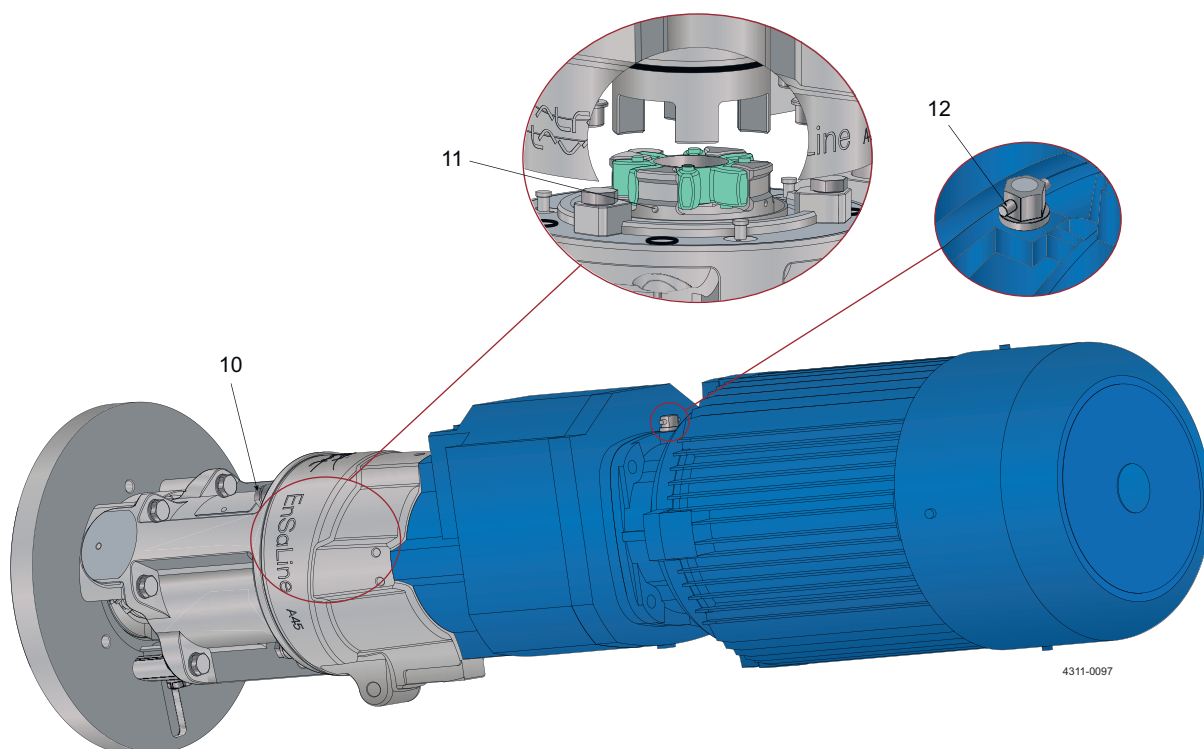

4311-0097

- 6 (Only applicable for seal type CD (Cartridge Double mechanical) with flush).
- a) Install the flush in- and outlet hose to the two Ø8 mm/0.31 inch push-in connection (13).

NOTE

The in- and outlet have no specified direction; the choice is left open.

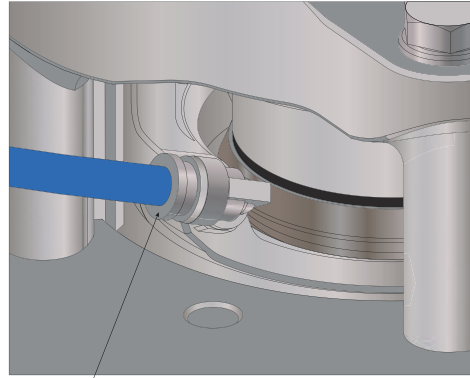

13

4311-0098

- a) Cut off the prepared slit on the seal cover to make an opening for the flush tube.

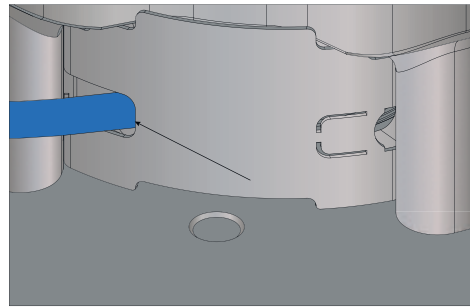

4311-0099

Always follow guidelines for flush media, see section [Connecting flush – seal type CD](#) on page 76.

- 7 Mount impeller device onto shaft.



Note thread direction.

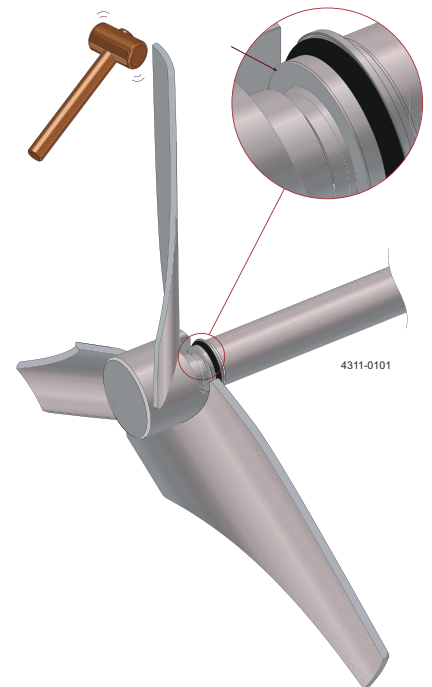
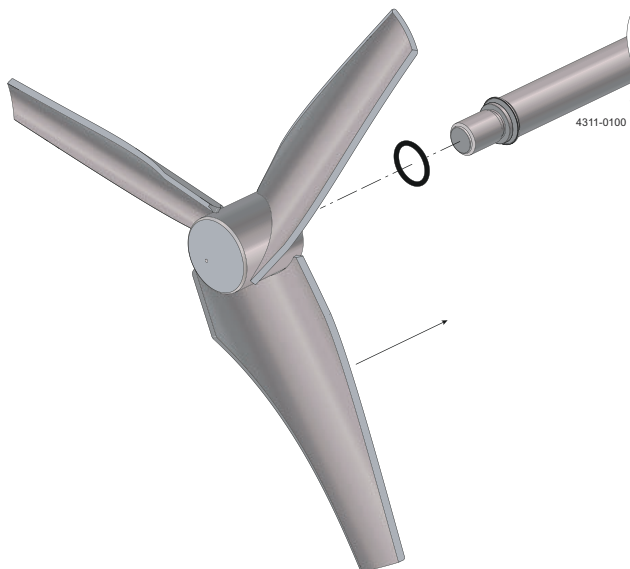

- 8 Ensure the impeller is positioned, keeping minimum radial distance to the tank bottom or side wall.

Clearance > $S/15$

and

Clearance > 100 mm/3.94 inch

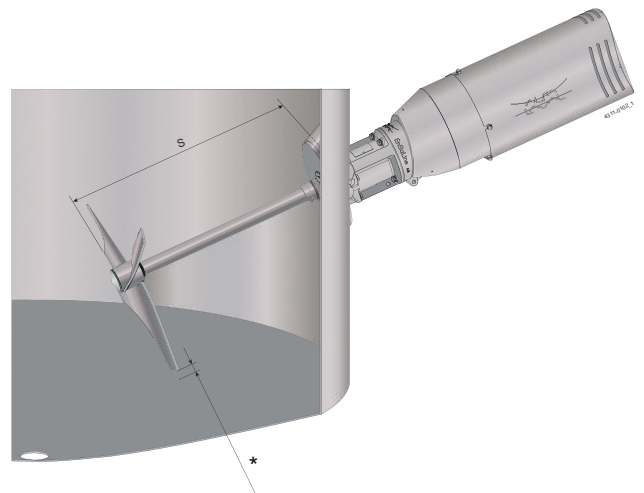

 **CAUTION**

Do **NOT** connect the power supply until installation is completed.

Ensure that the rotation direction is according to nameplate.

Always perform pre-use check before operation (see [Pre-use check](#) on page 29).

Alfa Laval recommends a soft starter or a frequency converter for the agitator to reduce the load on tank and agitator.

The ramp up and ramp down time should be about 2-5 seconds.

If frequency converter drive is used for variable speed operation, it must be ensured **NOT** to operate continuously within +/-20% of critical oscillation speed.

 **NOTE**

On closed tanks, Alfa Laval recommends installing a manhole circuit breaker, cutting power supply if hatch is open.

4.5 Pre-use check

WARNING

Never install the agitator in environments which deviate from those given in section *Intended use* on page 15 and *Technical Data* on page 75.

NOTE

Study the instructions carefully and pay special attention to the warnings!

Always check the agitator before operation.

Check the rotation direction before operation.

Always make sure that the motor corresponds to the environment.

- 1 Go through section *Safety precautions* on page 9.
- 2 Check the fastenings.
- 3 Check O-ring and impeller are correctly fitted.
- 4 Check impellers **CANNOT** collide with tank vessel at any point during a full rotation.

Clearance (*) > S/15

and

Clearance (*) > 100 mm/3.94 inch

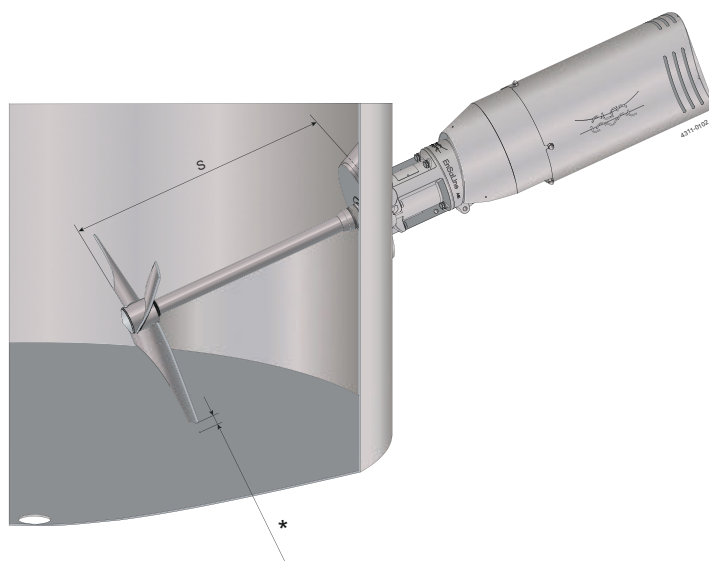

- 5 **Seal type CWS (Cartridge Wet Single mechanical)**
 - Ensure the sealing surfaces are not stuck together by slowly turning shaft by hand
 - Ensure that the seal is always submerged during operation

NOTE

Dry running will damage the seal faces.

6 Seal Type CD (Cartridge Double mechanical)

- Ensure the sealing surfaces are not stuck together by slowly turning shaft by hand
- Ensure that the seal never runs dry
- Ensure flush in- and outlet is connected and has a sufficient supply of flush media

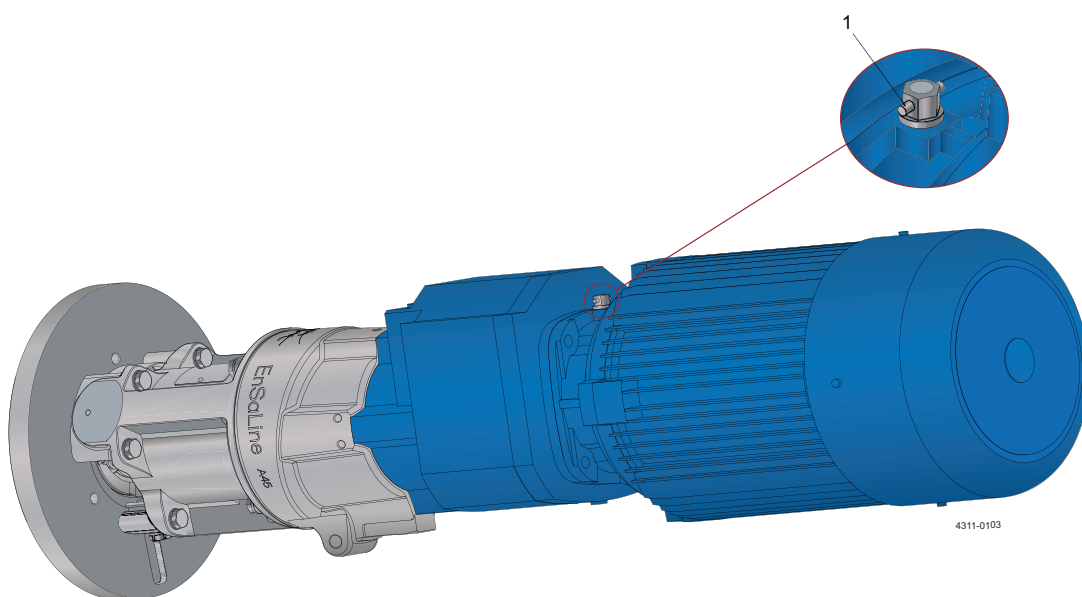
7 If the gear has a vent screw, make sure the vent points up. Remove the rubber plug (1).

- 8 Before starting the agitator ensure that the rotation direction is according to nameplate

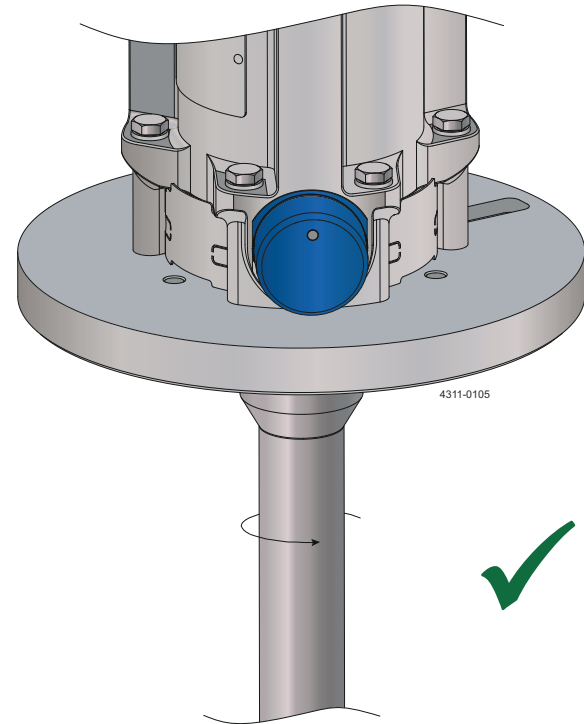
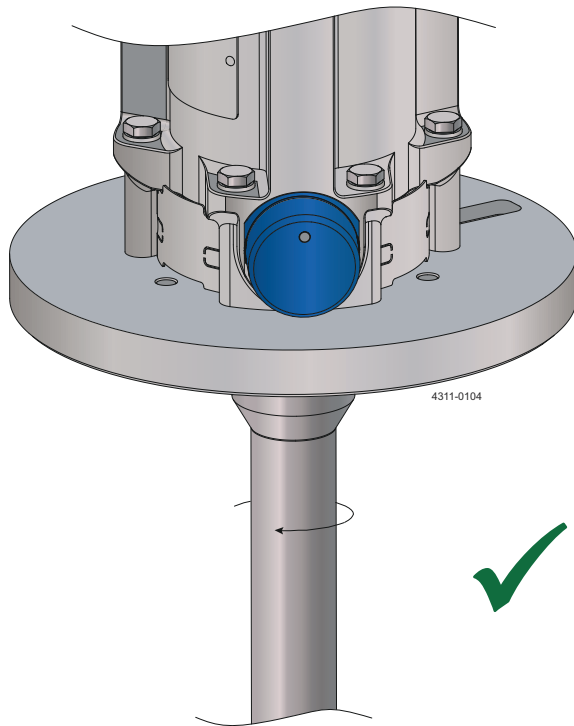

- 9 If frequency converter drive is used, it must be ensured NOT to operate continuously within $\pm 20\%$ of critical oscillation speed (see section *Intended use* on page 15 and *Technical Data* on page 75).

10 Check for oil leakage from the gearbox.

When side mounted an oil leakage from within the drive unit flange will collect in the inspection glass (2) near the drain.

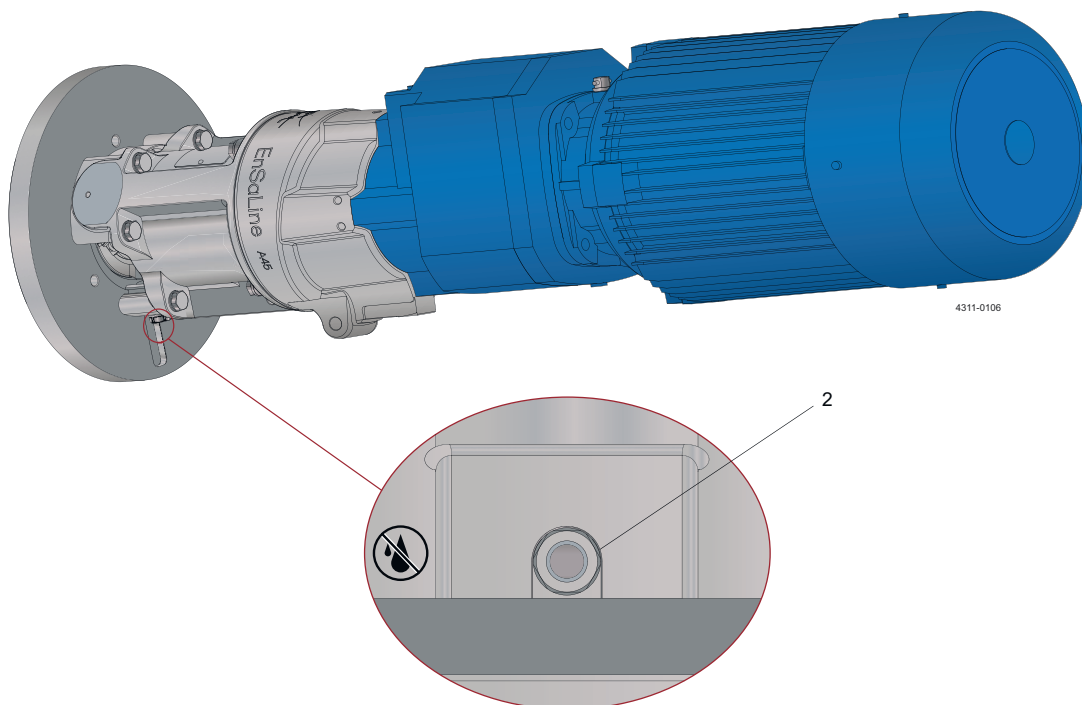

5 Operation

5.1 General operation

NOTE

Study the instructions carefully and pay special attention to the warnings!

Always check the agitator before operation - see [Pre-use check](#) on page 29.

Alfa Laval recommends a soft starter or a frequency converter for the agitator to reduce the load on tank and agitator. For operation instructions from suppliers (see chapter [Appendix](#) on page 95).

5.2 Operation/control

WARNING

If deviation from normal operation and intended use shown in section [Intended use](#) on page 15, immediately switch off the agitator and find the cause of failure (see section [Troubleshooting](#) on page 35).

The agitator is designed to max 5 starts per hour.

Inspect the agitator regularly

	Inspect / Clean / Lubricate				
	Supplier instruction	Weekly	Monthly	Half-yearly	Yearly
Drive unit					
Motor	x				
• Clean surfaces - to avoid overheating		x			
Gear	x				
• Clean vent screw (if any)		x			
• Check for oil leakage		x			
Flange					
Clean drain			x		
Sealing					
Mechanical seal					
• NOT flushed: CWS			x		
• Flushed: CD			x		
Drive train					
Clean PreVent screw		x			
Check spider clearance				x	
Check gaskets				x	
Lubricate radial seals				x	
Impeller device					

¹ If any suspicion of reduction in blade thickness, contact Alfa Laval and inform serial no stated on the name plate.

	Inspect / Clean / Lubricate				
	Supplier instruction	Weekly	Monthly	Half-yearly	Yearly
Sticky media					
• Clean impeller device			x		
Abrasive media					
• Check blade thickness ¹			x		
General					
Check bolt tension					x

¹ If any suspicion of reduction in blade thickness, contact Alfa Laval and inform serial no stated on the name plate.

Inspect service tool regularly

	Inspect / Clean / Lubricate				
	Before use	Weekly	Monthly	Half-yearly	Yearly
Hinge jack					
• Check for dents, bends and cracks	x				
• Worn-out bushings	x				
• General overhaul					x
Center jack					
• Check for dents, bends and cracks	x				
• Worn-out bushings	x		x		
• General overhaul					x
Shaft retainer					
• Check for dents, bends and crack	x				

5.3 Troubleshooting

Problem	Cause/result	Remedy
Not starting		
Drive unit	<ul style="list-style-type: none"> Defect Fault at power supply 	<ul style="list-style-type: none"> Dismantle drive unit. Check for correct rotation. Replace drive unit Check power supply connection Check voltage and frequency correspond with motor name plate Check frequency converter adjustment corresponds to name plate
Agitator	<ul style="list-style-type: none"> Obstructed 	<ul style="list-style-type: none"> Check agitator can rotate freely without striking anything
Vibrations		
Impeller device	<ul style="list-style-type: none"> Damaged Unbalanced impeller Damage to shaft seal 	<ul style="list-style-type: none"> Contact Alfa Laval Clean impeller device Replace sealing/bearing
Shaft	<ul style="list-style-type: none"> Damaged 	<ul style="list-style-type: none"> Contact Alfa Laval
Other	<ul style="list-style-type: none"> Deviation from normal operation Increased/decreased temperature 	<ul style="list-style-type: none"> Operation circumstances must be equal to those it was designed for¹
Unusual noise		
Drive train	<ul style="list-style-type: none"> Bearing gap Wear or damaged bearings Worn/damaged spider 	<ul style="list-style-type: none"> Replace bearings and all gaskets in bearing frame immediately Replace bearings and all gaskets in bearing frame Replace spider
Drive unit	<ul style="list-style-type: none"> Defect Bearing gap Increased/decreased power No grease 	<ul style="list-style-type: none"> Replace drive unit Renovate or change the drive unit immediately Switch off power supply Replace drive unit
Sealing	<ul style="list-style-type: none"> Worn sealing Seal is not flushed Seal surfaces stick together 	<ul style="list-style-type: none"> Replace sealing Replace sealing and ensure that the seal never run dry Separate surfaces carefully and clean them - ensure that seals are sufficient cleaned before stillstand
Other	<ul style="list-style-type: none"> Deviation from normal operation Circuit overload 	<ul style="list-style-type: none"> Operation circumstances must be equal to those it was designed for¹
Leakage		
Gear	<ul style="list-style-type: none"> Oil leakage 	<ul style="list-style-type: none"> Renovate or change the gear immediately

¹ See section [Intended use](#) on page 15

Problem	Cause/result	Remedy
Sealing	<ul style="list-style-type: none"> • CIP fluid or other • Set screws in coupling is loose 	<ul style="list-style-type: none"> • Replace sealing • Inspect seal and clean all surfaces. Follow instruction for seal replacement
<u>Continuous breakdown</u>		
Drive unit	<ul style="list-style-type: none"> • Defect • Too high frequency 	<ul style="list-style-type: none"> • Replace motor • Regulate frequency down
Other	<ul style="list-style-type: none"> • Deviation from normal operation 	<ul style="list-style-type: none"> • Operation circumstances must be equal to those it was designed for¹
<u>Performance</u>		
Drive unit	<ul style="list-style-type: none"> • Wrong frequency 	<ul style="list-style-type: none"> • Check frequency connection
Agitator	<ul style="list-style-type: none"> • Reverse direction 	<ul style="list-style-type: none"> • Inspect the agitator carefully
Other	<ul style="list-style-type: none"> • Deviation from normal operation 	<ul style="list-style-type: none"> • Operation circumstances must be equal to those it was designed for¹

¹ See section [Intended use](#) on page 15

5.4 Cleaning recommendations

WARNING

Ensure the drain in flange is not clogged up by cleaning drain regularly.

Ensure that all surfaces in contact with product are totally clean in order not to contaminate the product.

Pay special attention to:

- Impeller device surfaces
- Surfaces between impeller devices and shaft
- Surfaces around sealing
- Surfaces around weldings

CAUTION

Mechanical seals are designed for cleaning in place (CIP) and sterilising in place (SIP).

NOTE

Always rinse well with clean water after the cleaning.

5.5 Temperature limits

The highest allowable ambient temperature is 40°C/104°F.

Gear box:

The highest allowable continuous temperature of the SHAFT that goes into the gear motor is 105°C/221°F.

Shorter periods with higher application temperatures, eg. 10-20 minutes during a sterilization phase or the like, can be allowed and accepted without changing the oil service interval and without reducing the lifetime of the gear motor.

If longer periods with exceeded application temperatures are required, the actual temperature of the oil in the gear motor must be measured.

The highest allowable oil temperature is 140°C/284°F and the oil service interval, which at 70°C/158°F is about 40.000 hours, will be reduced by 50% for each 15 degrees the oil temperature is increased above the 70°C/158°F.

Bearing housing/frame:

The highest allowable continuous temperature of the SHAFT that goes into the bearing frame is 105°C/221°F.

Shorter periods with higher application temperatures, eg. 10-20 minutes during a sterilization phase or the like, can be allowed and accepted without changing the service interval and without reducing the lifetime of the bearings.

If longer periods with exceeded application temperatures are required, the actual temperature of the bearings must be measured.

The highest allowable bearing temperature, without changing the service interval, is 120°C/248°F.

5.6 Pressure limits

The side and bottom mounted agitator can be equipped with different shaft seal types with different operating properties.

The shaft seal is selected according to the application.

In the table below you will find the maximum allowable tank pressure during operation for the different seal types.

Seal type	Tank pressure (barg/psig)		Designation
	Min.	Max.	
CWS	-1.0/-14.50	6.0/87.0	Single mechanical shaft seal. High pressure and high speed
CD	-1.0/-14.50	6.0/87.0	Double mechanical shaft seal w. flush. High pressure and high speed

NOTE

Above pressures are not taking limitations on flange connections according to local pressure regulations into consideration.

Be aware that the operating pressure limits for the shaft seal can be lower than the tank design pressure.

6 Maintenance

6.1 General maintenance

WARNING

For lifting instruction, please refer to chapter [Installation](#) on page 17.



WARNING

Maintenance of the agitator should only be performed by authorized personnel.

Always read the [Technical Data](#) on page 75 thoroughly.

Always ensure that the mounting is according to [Intended use](#) on page 15 and chapter [Technical Data](#) on page 75.

Always disconnect the power supply when servicing the agitator.

Always use proper tools.

Always replace worn sealing elements before reassembling.

Follow the dismantling and assembly instructions to the letter.

After maintenance, section [Pre-use check](#) on page 29 must be read thoroughly before operation.

NOTE

Read the instructions carefully.

The items refer to the parts lists in section [Parts Lists and Exploded Views](#) on page 83

For maintenance instructions from suppliers, see chapter [Appendix](#) on page 95.

Ensure totally clean surfaces during mounting - also remove remaining loctite residue on threads.

Always refer to tightening torques in section [Tightening torques for bolt connections](#) on page 78.

All scrap must be stored/disposed of in accordance with current rules and directives.

Always use original Alfa Laval spare parts.

6.1.1 Preventive maintenance

To ensure that your Alfa Laval machine operates efficiently, it is essential to follow a simple preventive maintenance programme, which will keep your machine in good working conditions. Good maintenance requires careful attention at regular intervals!

The following recommended preventive maintenance procedures are based on the average operating conditions of most Alfa Laval machines. However, you will appreciate that a machine, which is subject to rough and dirty conditions, will need more frequent attention than one working in ideal conditions. We trust that you will adjust your maintenance programme to meet the demands of your normal operating conditions.

	Replace every:				
	500 hours or yearly	1000 hours or yearly	3000 hours or yearly	6000 hours or every 3rd year	10000 hours or every 3rd year
Sealing					
Static seals					x
Radial seals			x		
Mechanical seal					
• NOT flushed: CWS				x	
• Flushed: CD					x
Drive train					
Spider coupling					x
Bearings, rpm < 700					x
Bearings, rpm > 700				x	
Service tools					
Hinge jack Center jack	General overhaul yearly				

6.2 Replacement of seal cartridge and top bearing

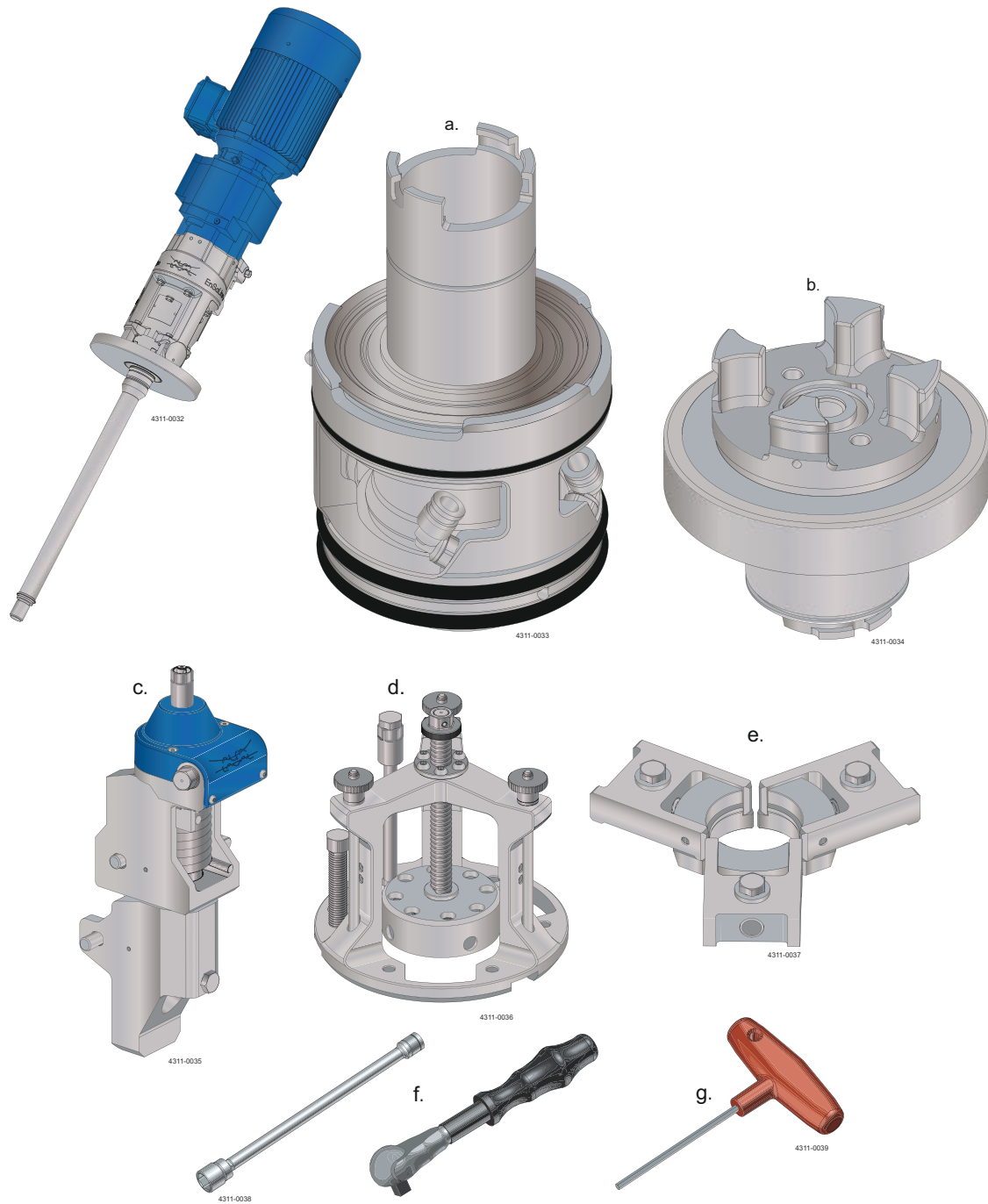

Replacement parts and tools

1 Prepare the following replacement parts and tools:

- a) Replacement seal cartridge
- b) Replacement top bearing assembly (if needed)
- c) Hinge jack
- d) Center jack
- e) Shaft retainer
- f) Spanner, size 17 mm/0.67 inch
(Preferred a ratchet spanner with a flexible head)
- g) Allen key, size 3 mm/0.12 inch

2



WARNING

Electricity

Ensure that the power to the drive unit is disconnected and locked out before proceeding.



- a) Adjust the hinge jack to have a gap of 5 mm/0.20 inch between the upper and lower part by turning the nut on the top (1).
- b) Then attach the hinge jack to the agitator housing by mounting the lower pin (2) first.
- c) Align the hole in the upper part with the hole in the drive unit flange by turning the nut on the top (1) and attach the second pin (3).

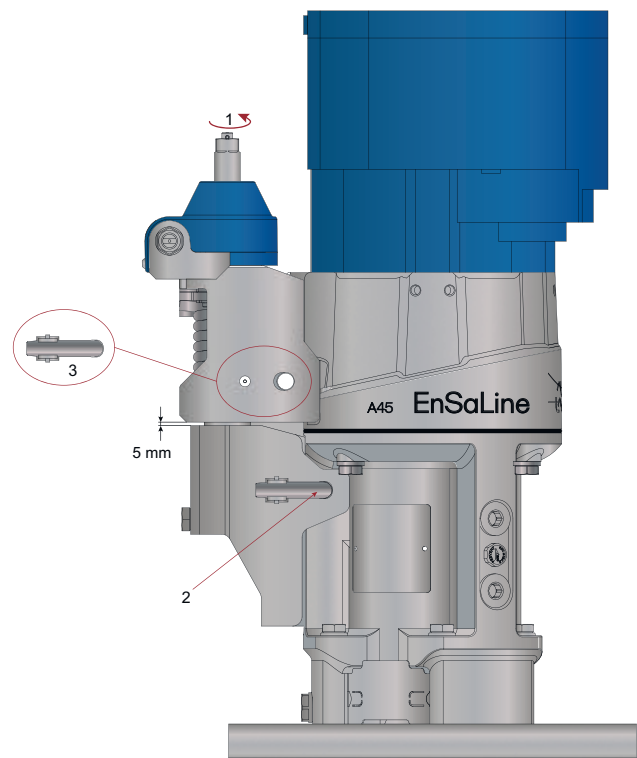

4311-0040

- 3 The drive unit is now secured to the hinge jack and is now ready for separation.

a) Loosen the 4 screws (1) in the drive unit.

NOTE

When loosening, start with screws closest to the hinge jack and when tightening start with the screws farthest away from the hinge jack. This is to avoid bending/ stressing the screws as the drive unit sinks until it rests on the hinge jack.

b) When loose pull the screws back and engage them with the captive thread (2) in the housing to hold them back. This comes in handy when the agitator is bottom-mounted.

c) Lift the drive unit approximately 30 mm/ 1.18 inch up by turning the nut on the top (3). This is to separate the coupling parts from each other and give a clear passage for the turning.

NOTE

Do not use power tools of any kind.

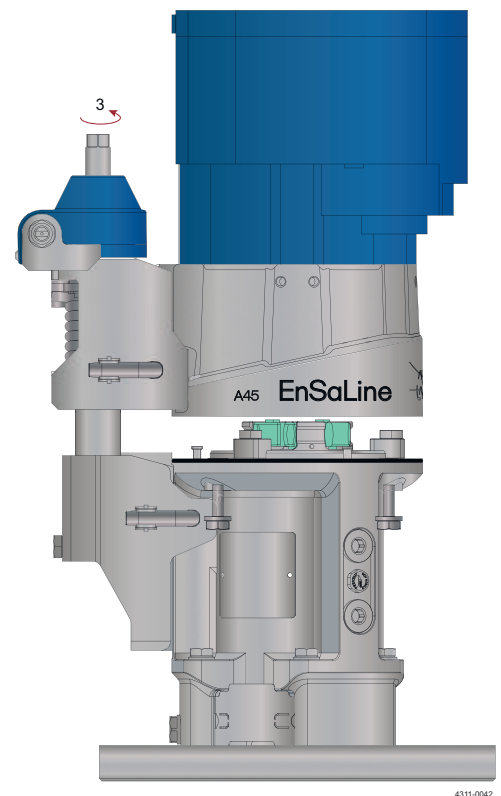
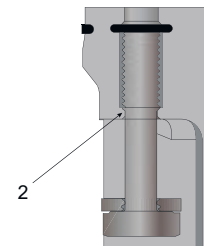
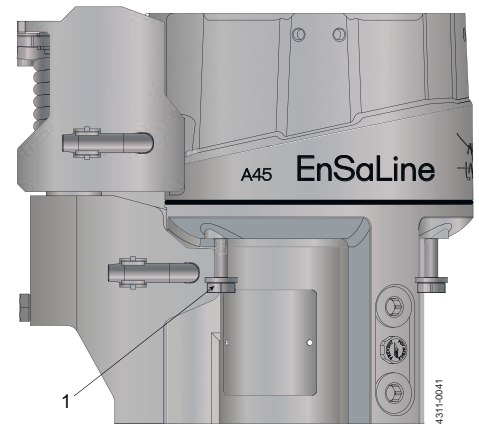

- d) Turn the drive unit approximately 90 degrees to the side by turning the worm screw (4) counterclockwise on the side of the hinge jack.

! NOTE

Do not use power tools of any kind.

- e) Remove the spider (5) and replace it if it is needed.

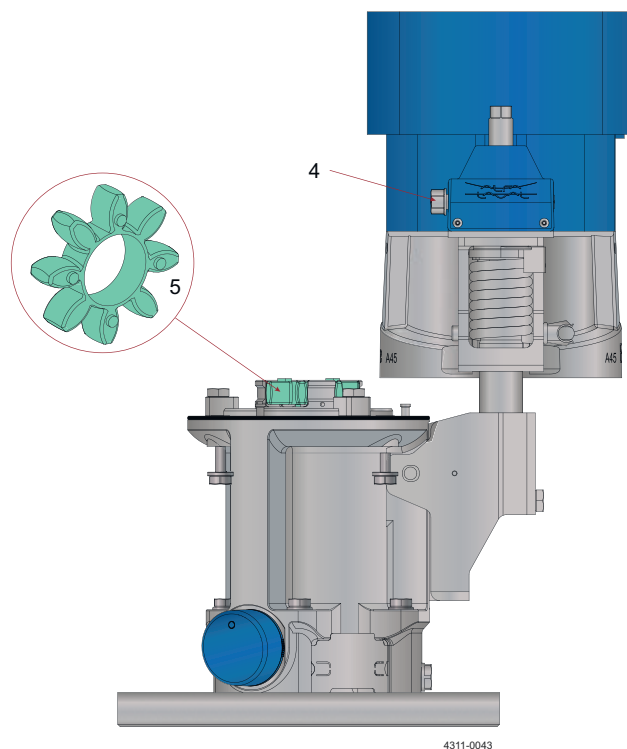

- 4 The agitator is now ready for attaching the center jack.

- a) Attach the center jack by twisting the mushroom pins (1) clockwise into the mushroom connectors (2).

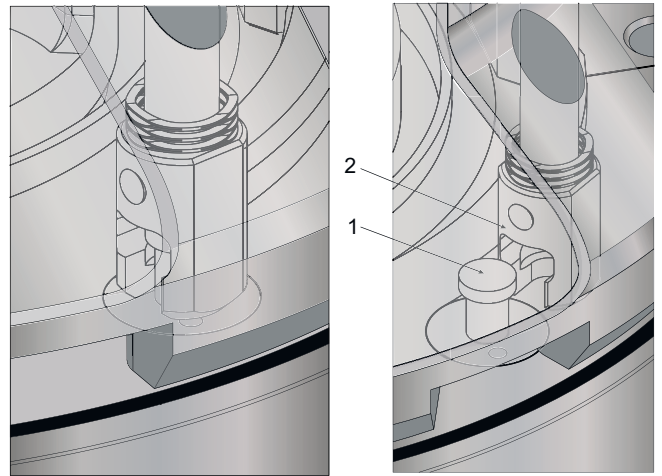

4311-0073

- b) Keep applying a light twist while tightening the finger nuts (3).

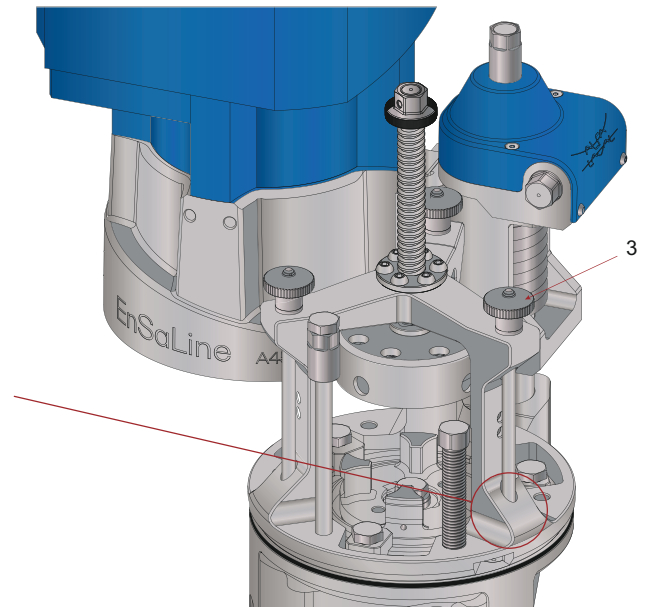

4311-0044

- c) Attach the swivel joint (1) to the agitator coupling by aligning the holes on the side (2) with the claws on the coupling and screw the center screw (3) all the way down.

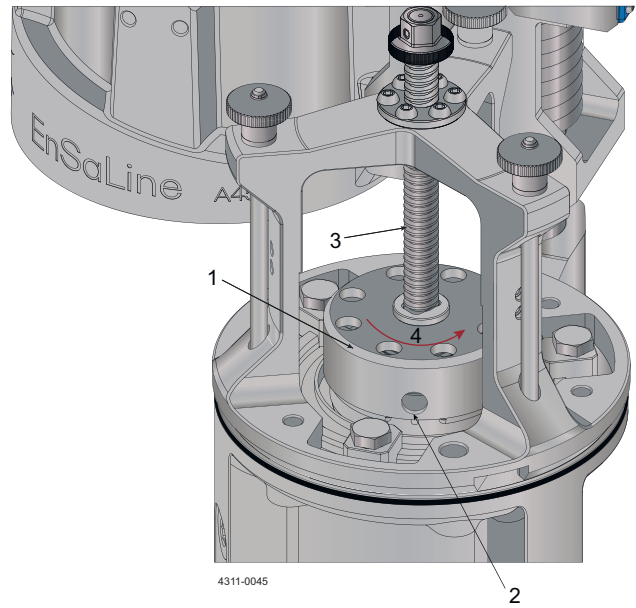

- d) Apply light twist (4) on the swivel joint while turning the center screw back to engage the lock (5) between the swivel joint and the coupling.

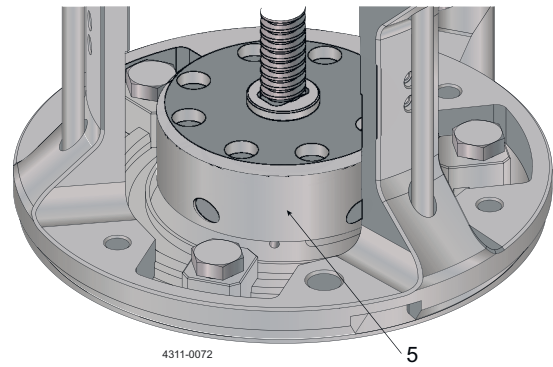

5 The center jack has been attached and securely fastened to the shaft. It is now prepared for release from the housing.

- a) Screw down the center screw on the center jack to apply a slight pressure on the coupling (1), locking the shaft into position.

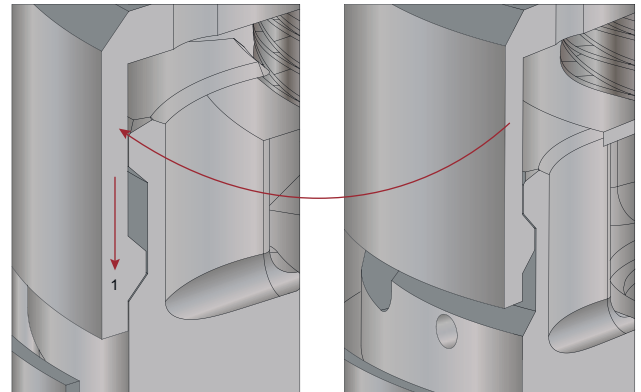

4311-0046

- b) Next, loosen the 3 screws (1) that hold the top bearing in place and screw them approximately 6 mm/0.24 inch back and flip the spacer blocks (2) 180 degrees. Then slightly tighten the screws again to fix the spacer blocks in a position that allows free passage of the top bearing assembly.

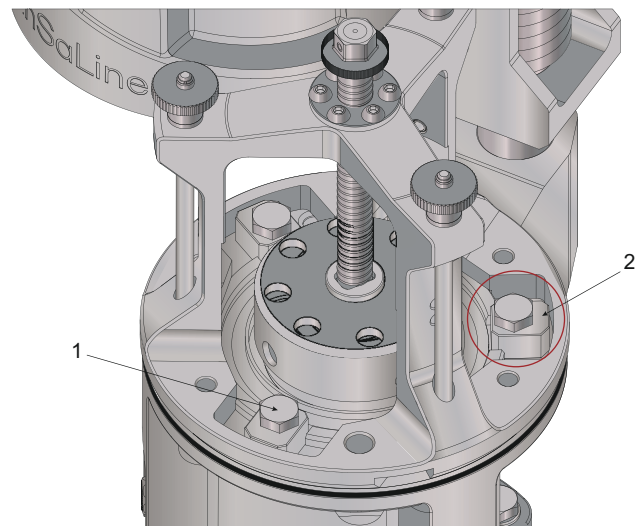

4311-0047

- c) Remove the 3 cover plates (1) with the Allen key.

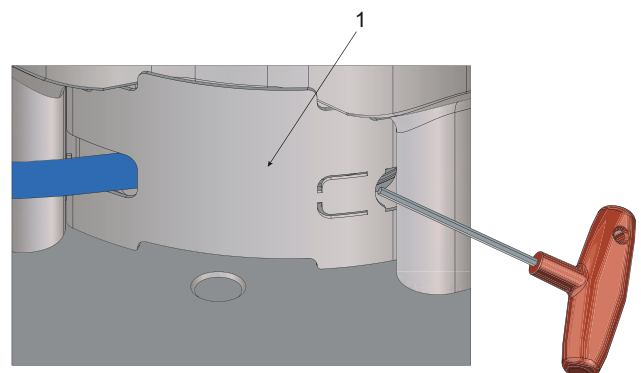

4311-0048

- d) If the seal cartridge is arranged with flush, then remove the 2 flush tubes (2).

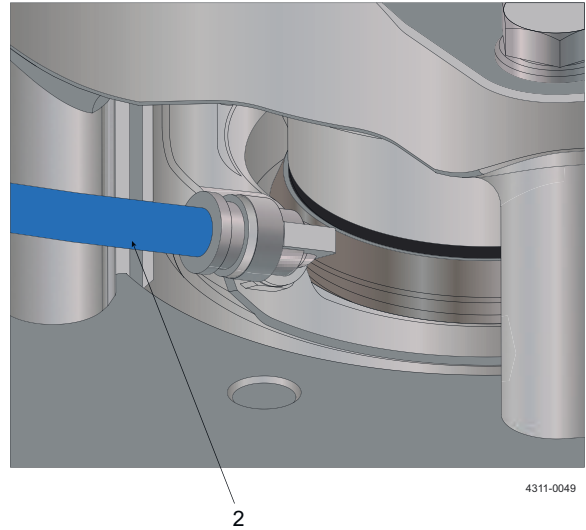

- e) Flip the 2 fittings (3) inside the seal cartridge so they do not interfere with housing when pulling back the shaft.

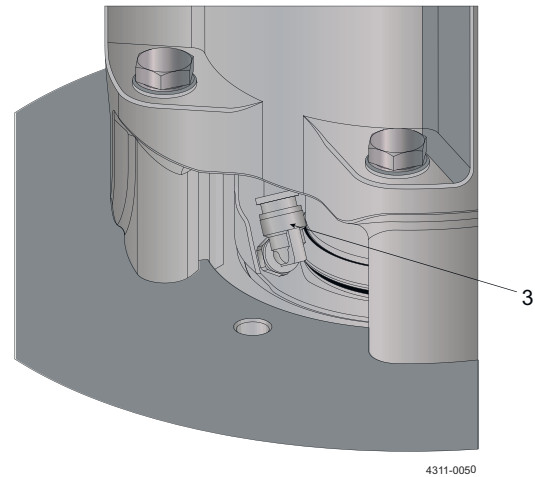

- f) Screw back the center screw to pull the shaft with the seal cartridge and the top bearing assembly back out of the housing. Pull it back until the oil trap (1) is aligned with the first spring-loaded steel ball (2).

NOTE

Do not use power tools of any kind.

- g) With a light push, pop the oil trap between the two spring-loaded steel balls (3) to secure it to the center jack for later removal.

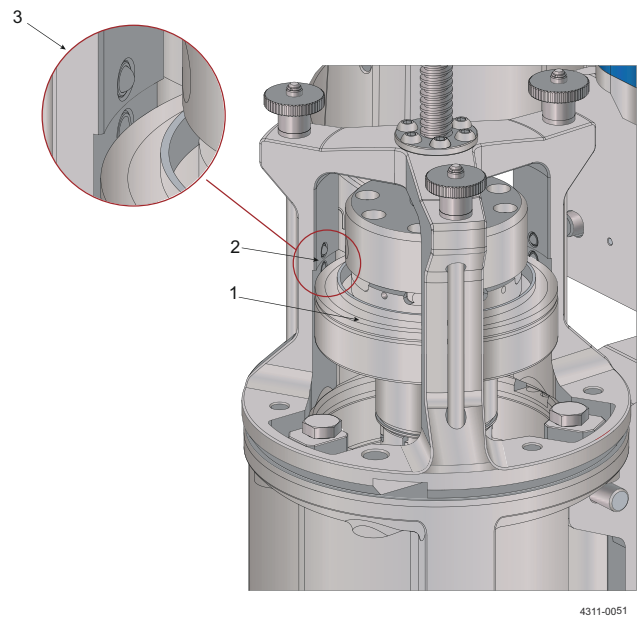

- 6 The agitator shaft is now ready to attach the shaft retainer and lock it to the welding flange.

- a) Attach the shaft retainer to the welding flange with the screw (1) by sliding the clamp into the groove of the shaft (2).



Do not tighten the screw yet. It just needs to get a hold on the thread in the flange.

The magnet (3) inside the retainer tool will pull the tool into the groove of the shaft and hold it perpendicular to the shaft while the shaft and tool will be lowered into the conical face (4) of the welding flange.

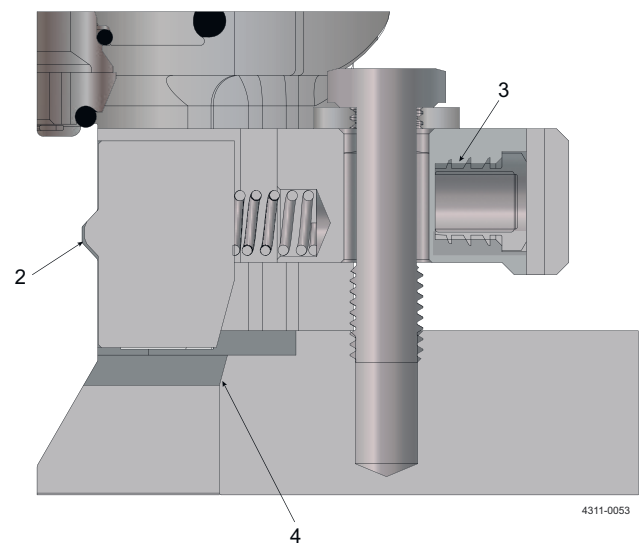
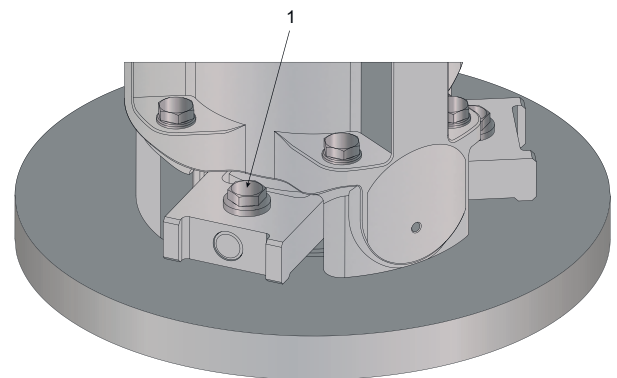

- b) Turn the center screw down until the retainer tool meets the conical face of the welding flange and tighten the screw with a torque of maximum 50 Nm/36.88 ft lb.



Do not use power tools of any kind.

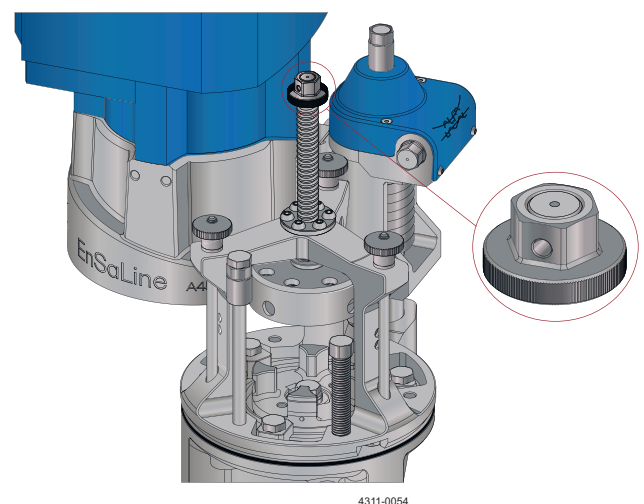

- c) Tighten the 3 screws (1) on the shaft retainer tools evenly with a torque of 50-80 Nm/36.88 to 59 ft lb.

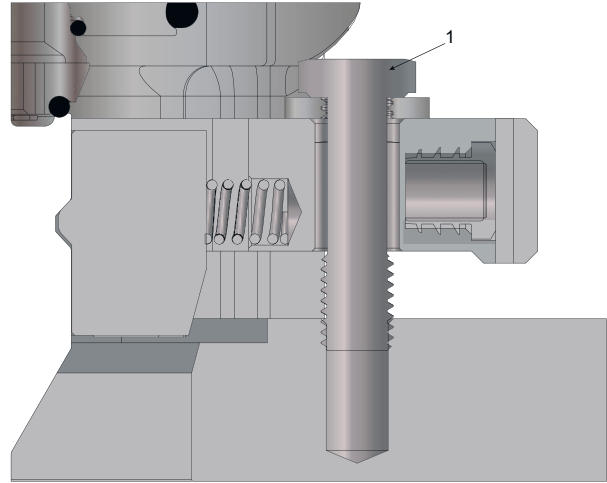

4311-0055

- d)

NOTE

To ensure good alignment and easy disassembly it is recommended to tighten the screws in a sequence like the following:

10 Nm/7.38 ft lb A, B and C

followed by 30 Nm/22.13 ft lb A, B and C

and final 60 Nm/44.25 ft lb A, B and C

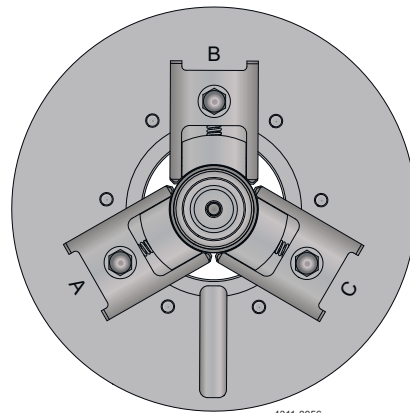

4311-0056

- 7 The agitator shaft is now tightly secured to the welding flange. The center jack can now be removed to give access to the top bearing assembly and the seal cartridge.
- The swivel joint stands with a pressure against the coupling from the previous step 6.b and can be detached from the coupling using the same method as described in step 4.c but instead of engaging the lock it will be disengaged.
 - You can then align the hole on the side of the swivel joint with the claws of the coupling as described in step 4.b and detach them from each other.

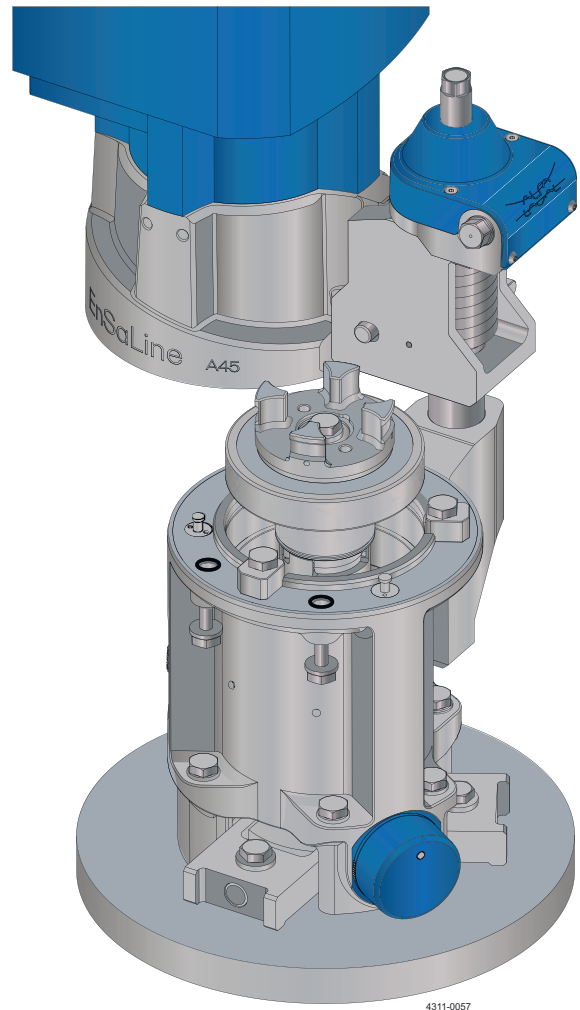

- Loosen the finger nuts. Press down and twist the center jack out of its mushroom connectors as shown in step 4.a and pull it off the bearing. Place it aside for later use.

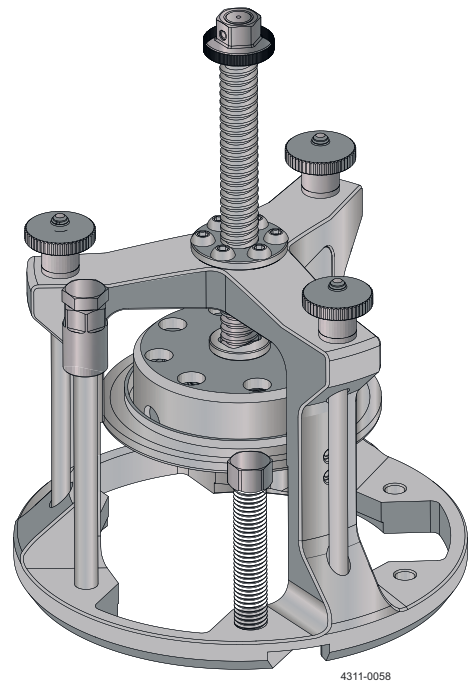

8 The agitator is now ready for replacing the top bearing assembly (if needed) and the seal cartridge.

a) Unscrew the bolt (1) connecting the coupling with the shaft.

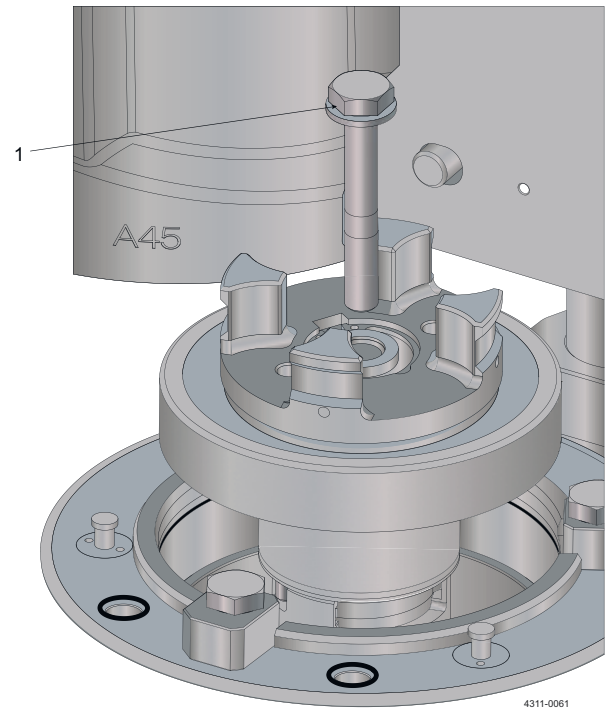

b) Next, pull back the top bearing assembly which is connected to the seal cartridge. If needed the puller screw (2) can be used for this purpose.

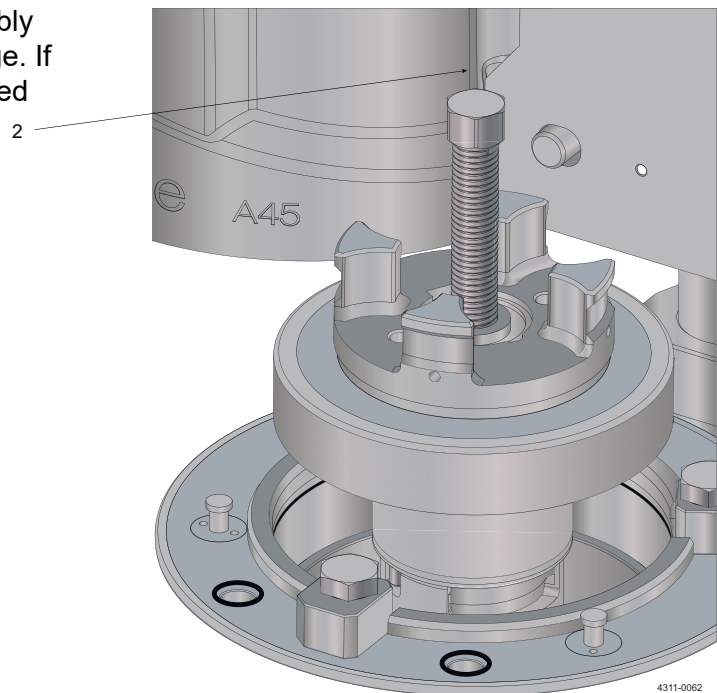

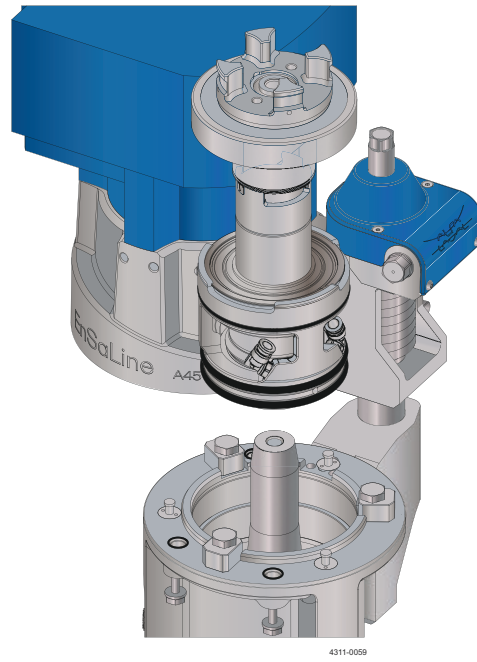
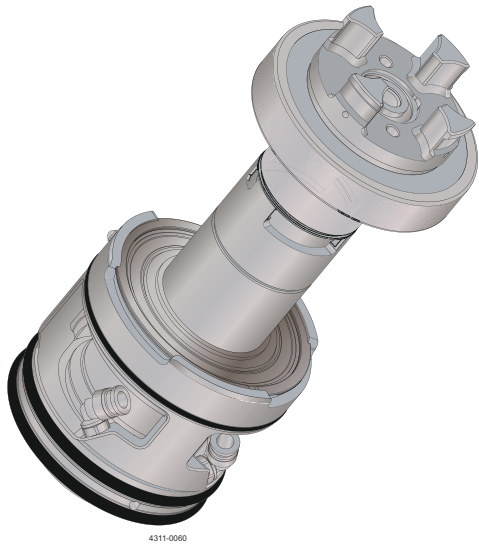

9 Provided the top bearing has not reached end of life, it can be reassembled with a new or refurbished seal cartridge.

- a) With the Allen key, screw back the 2 set screws (1) in the coupling to open the lock between the coupling and the seal cartridge.

NOTE

On assembly of the two parts again it is important not to tighten the set screws (2) until coupling has been screwed onto the shaft. Until that, the set screws should only be screwed down to the position where the two parts lock together.

The two parts should be able to move ± 1.5 mm/0.06 inch (A) lengthwise of each other.

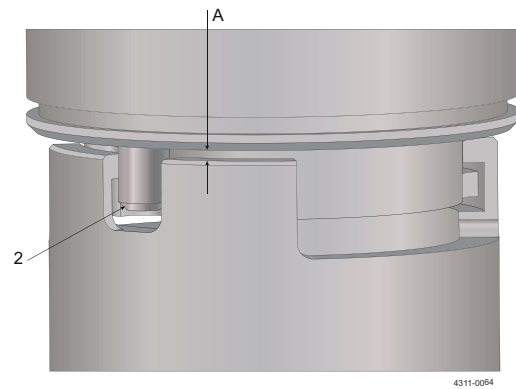
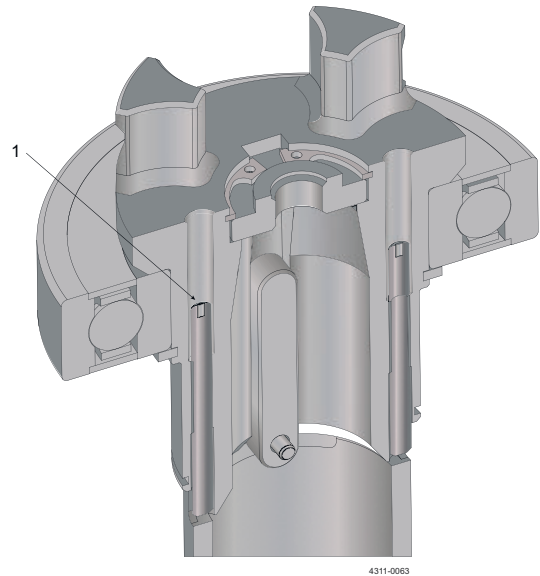

- b) The two parts can now be disengaged by twisting 90 degrees towards each other.

NOTE

Before mounting, apply grease to the sliding faces of the replacement parts as follows: the top bearing outer ring (1), the seal cartridge outer ring (2), and seal cartridge inner surface (3).

Also apply food approved grease to the O-rings on the seal cartridge.

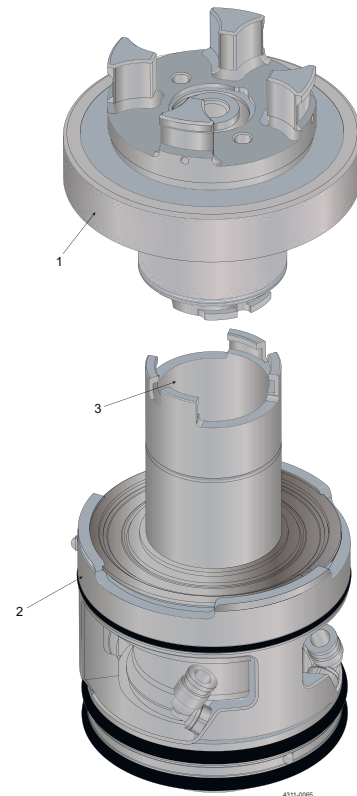

- 10** The agitator is now ready to install the replacement parts.

- a) Ensure aligning the seal cartridges rotational stop (1) with the groove (2) in the housing when sliding it down the shaft.

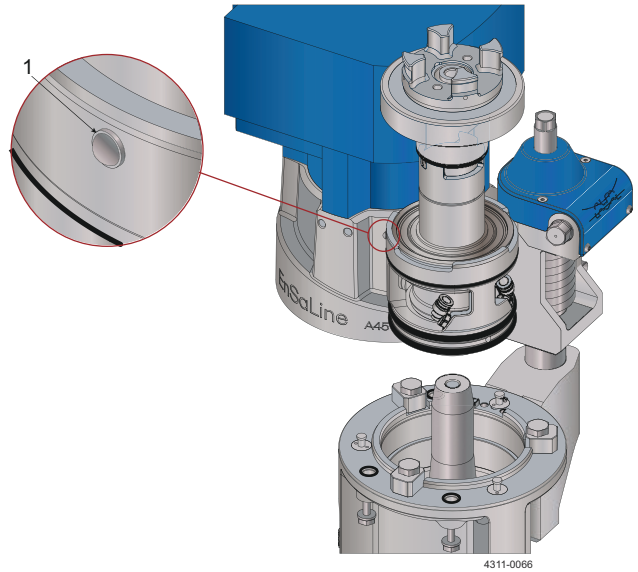

- b) In case the shaft has a parallel key (3), the keyway in the coupling must be oriented according to the rotational stop (1) so that both match up with the shaft and housing when mounted.

NOTE

If the shaft and housing have been misaligned, the seal cartridge may need to be forced on which can be achieved with the push rod and nut (4).

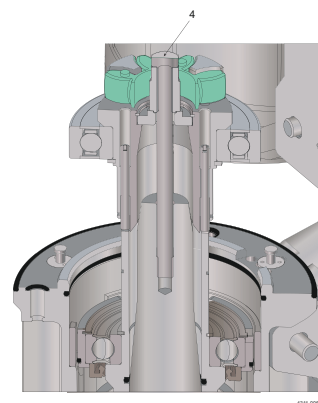
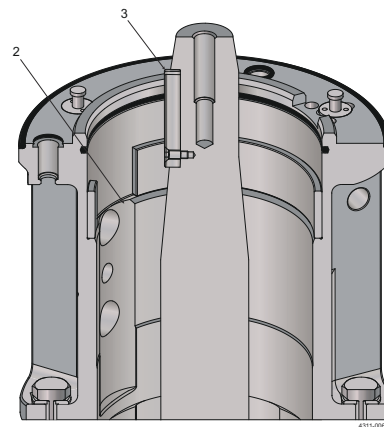

- c) Screw in the bolt (1) connecting the coupling with the shaft. Tighten it to 50 Nm/36.88 ft lb.

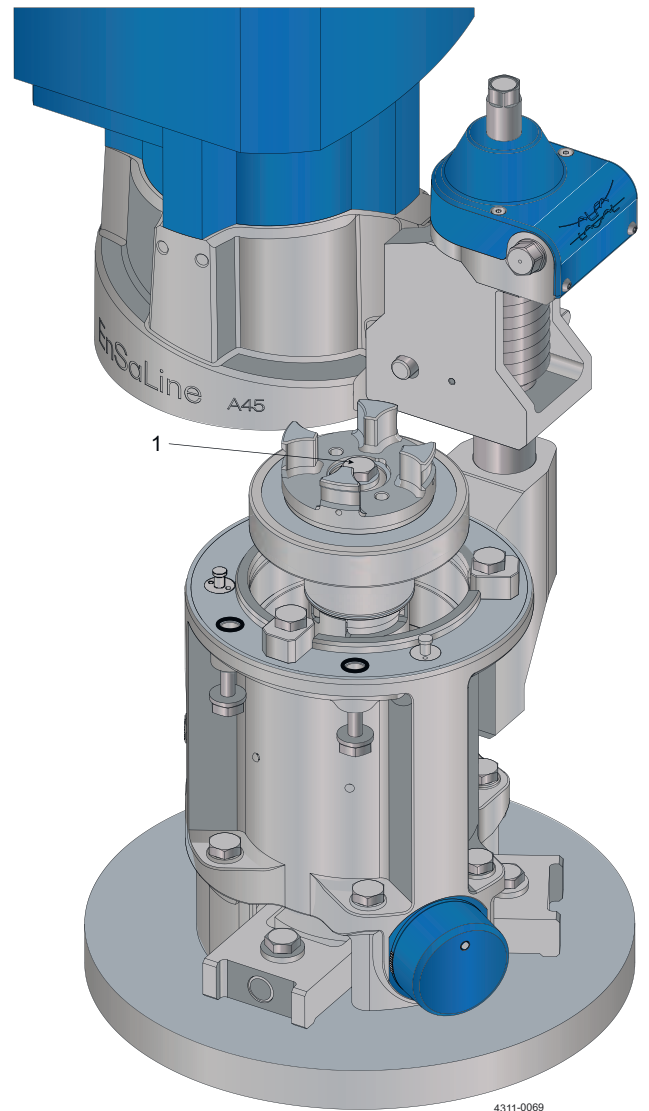

4311-0069

- d) Next, tighten the set screws (2) to 10 Nm// 7.38 ft lb. This will push the seal cartridge forward and compress the lower O-ring (3) against the shaft for a proper sealing.

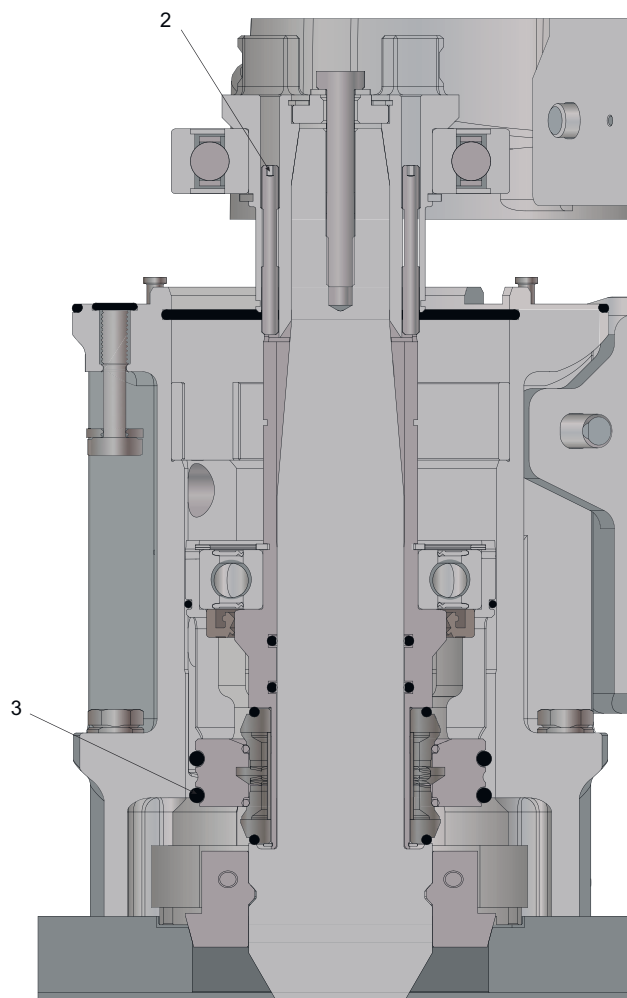

4311-0070

- 11 The agitator is now ready to be re-assembled in the same way as it was dismantled.
- a) Attach the center jack as described in step 4 and apply a light pressure down against the coupling.
 - b) Loosen the screws in the 3 shaft retainer tools and screw them back to the position as described in step 6.a so the retainer tool can move freely up when the shaft is lifted.
 - c) Screw back the center screw on the center jack until the oil trap is aligned with the first spring-loaded steel ball as described in step 5.f and remove the shaft retainer tools.



Do not use power tools of any kind.

- d) With the center screw in the center jack, lower down the shaft until the top bearing rest in the housing and push down the oil trap ring which is holding in the spring-loaded steel balls on the center jack.



Do not use power tools of any kind.

- e) Flip the 3 spacer blocks back into position as described in step 5.b and tighten them to 50 Nm/36.88 ft lb.
- f) Remove the center jack as described in step 7.
- g) Attach the spider as described in step 3.e and turn back the drive unit in the opposite direction as described in step 3.d.



Do not use power tools of any kind.

- h) Align the claws of the two coupling parts so that they merge easily. Use the Allen key and the holes (1) in the coupling for easy alignment.
- i) Lower down the drive unit by turning the nut on the top on the hinge jack as described in step 3.c. Stop when Drive unit gets in contact with the housing.

! NOTE

Do not use power tools of any kind.

- j) Screw in the 4 screws as described in step 3.a and tighten to 50 Nm/36.88 Nm.
- k) Pull the pins in the hinge jack and remove it.

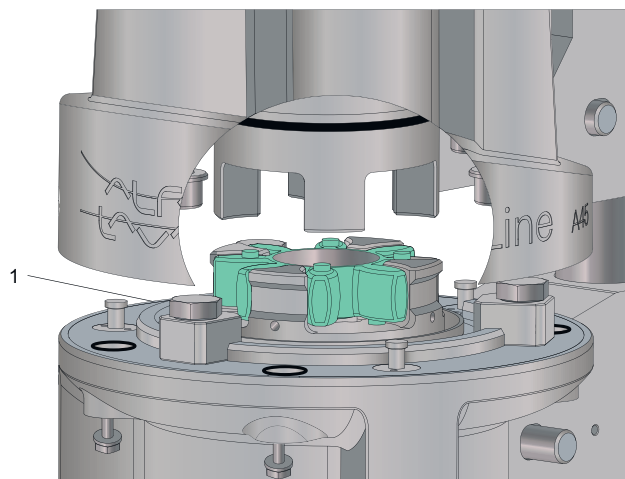

4311-0071

The service is now complete.

6.3 Replacement of seal faces and lower bearing

The Seal Cartridge is available in different elastomer and seal face material combinations. It is important that correct Alfa Laval original spare parts are used.

Overall, two types are used:

- CD (Cartridge Double Seal), as below
- CWS (Cartridge Wet Seal), as below (but without positions 9-1, 10-1, 11, 12, 13-1, 14-1)

Instructions below are made for CD.

CWS instructions referring to parts with positions 9-1, 10-1, 11, 12, 13-1, 14-1 should not be performed.

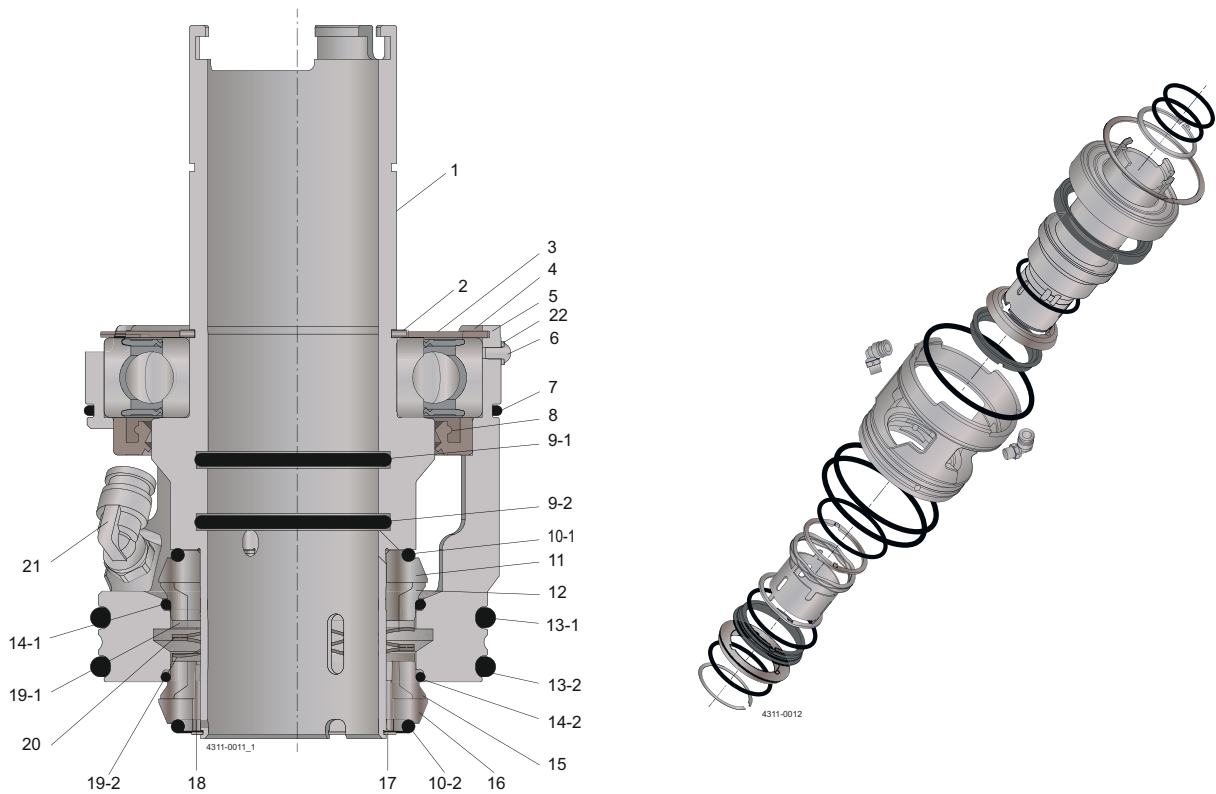

- 1 A clean and safe working environment with sufficient lightning is highly recommended.

Prepare the following tools and spare part kits:

- a) Flat-head screwdriver (2-3 mm/0.08-0.12 inch width)
- b) Snap-ring-pliers (for $\text{Ø}40\text{-}\text{Ø}55$ mm/
 $\text{Ø}1.57\text{-}2.17$ inch external retainer rings)
- c) Workshop-press with appropriate part (rings etc.) for pressing
- d) Spare Part Kit for Seal Cartridge
- e) Food approved mounting grease for O-rings
- f) Cleaning alcohol and paper

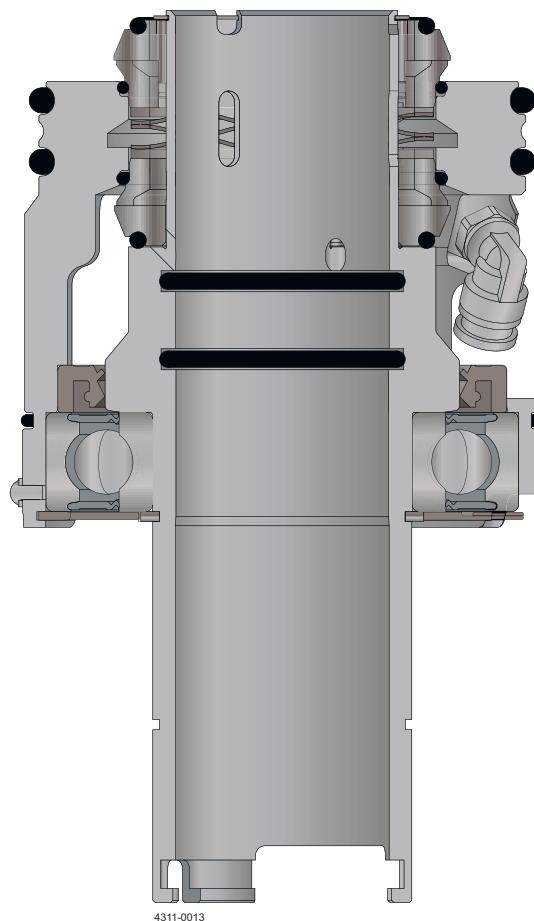

4311-0013

- 2 Place the Seal Cartridge on a clean work bench with the seal faces (16) pointing upwards.
- a) Remove O-rings (7, 10-2, 13-1, 13-2) and dispose of them.



Follow approved recycling procedures.

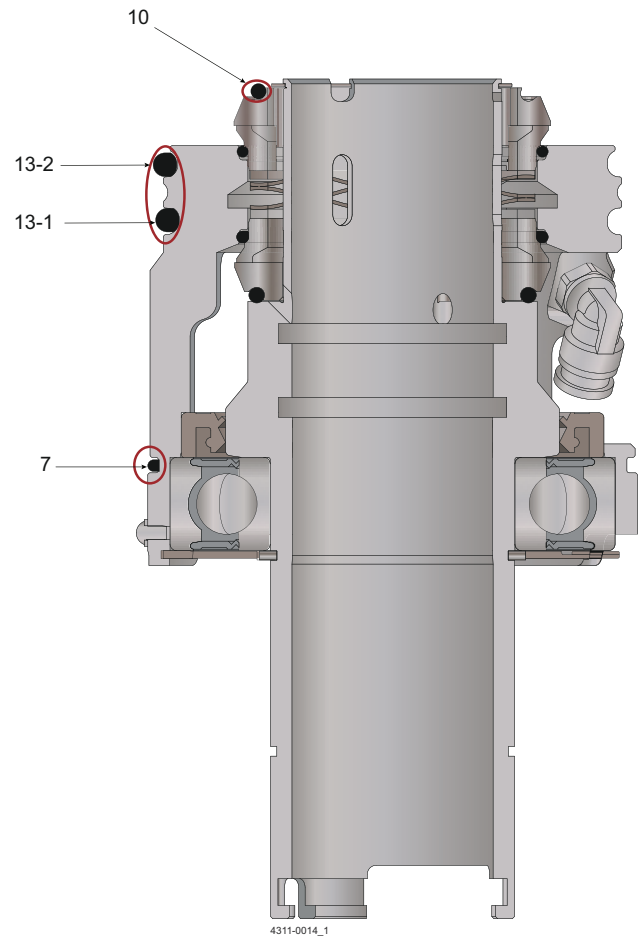

3

- a) Remove retainer ring (17) by using a small flat-head screwdriver at the end of the retainer ring.

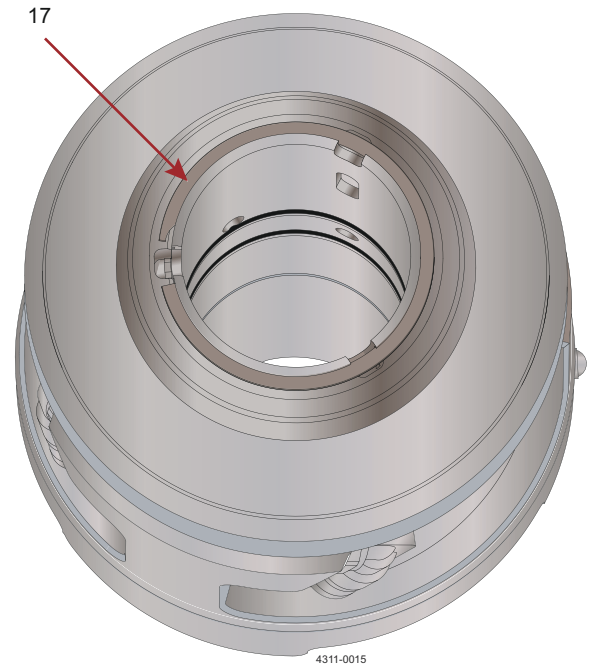

- b) Remove seal faces (16, 15) and dispose of them.



Follow approved recycling procedures.

- c) Remove O-ring (14-2) and dispose of it.



Follow approved recycling procedures.

- d) Remove distance ring (18).

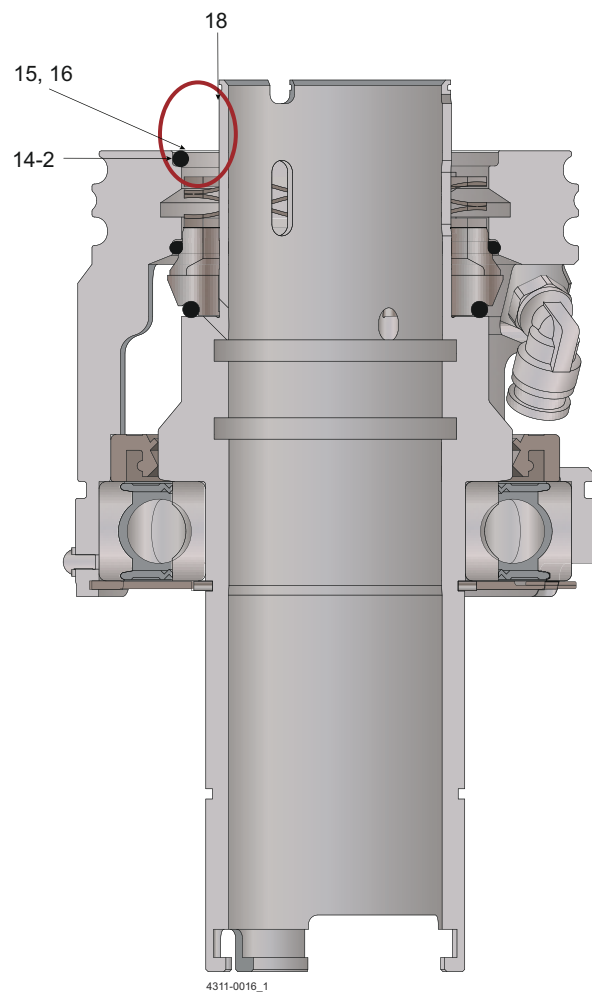

- 4 Turn the Seal Cartridge upside down with the bearing (3) pointing upwards.

- a) Remove retainer ring (4) by using a small screwdriver at the opening end of the retainer ring.

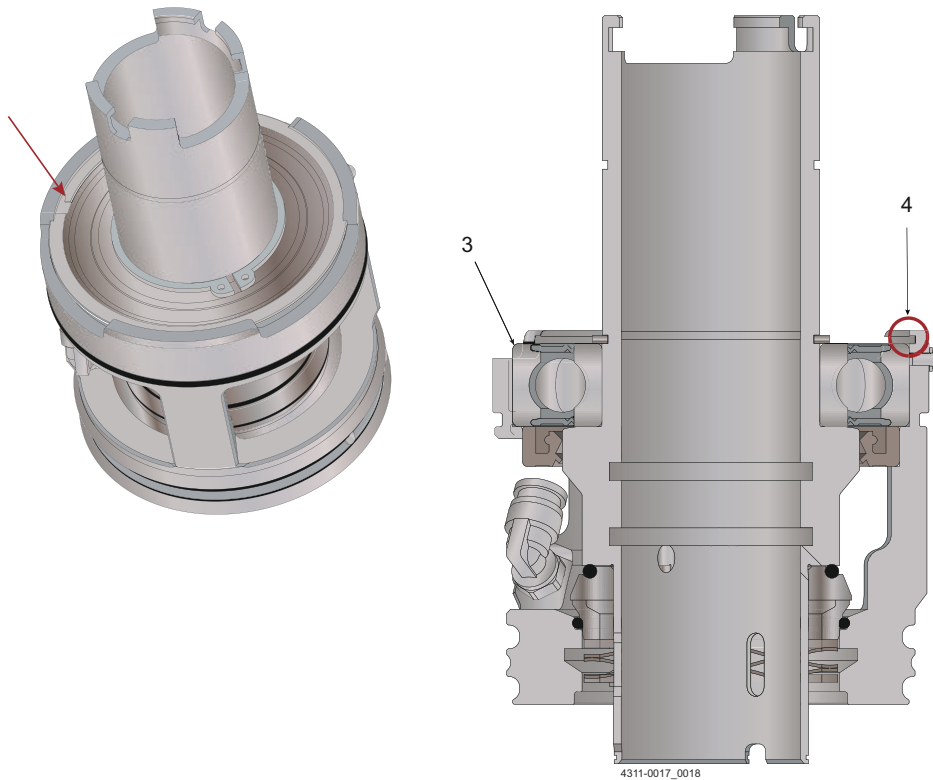

- 5 Turn the Seal Cartridge upside down with the bearing (3) pointing downwards.
- Place the Seal Cartridge house (5) in a suitable workshop-press on a ring (A) that enables the Seal Cartridge house to stand safely.
 - Place a ring (B) on top of the sleeve (1) and press out the bearing (3).

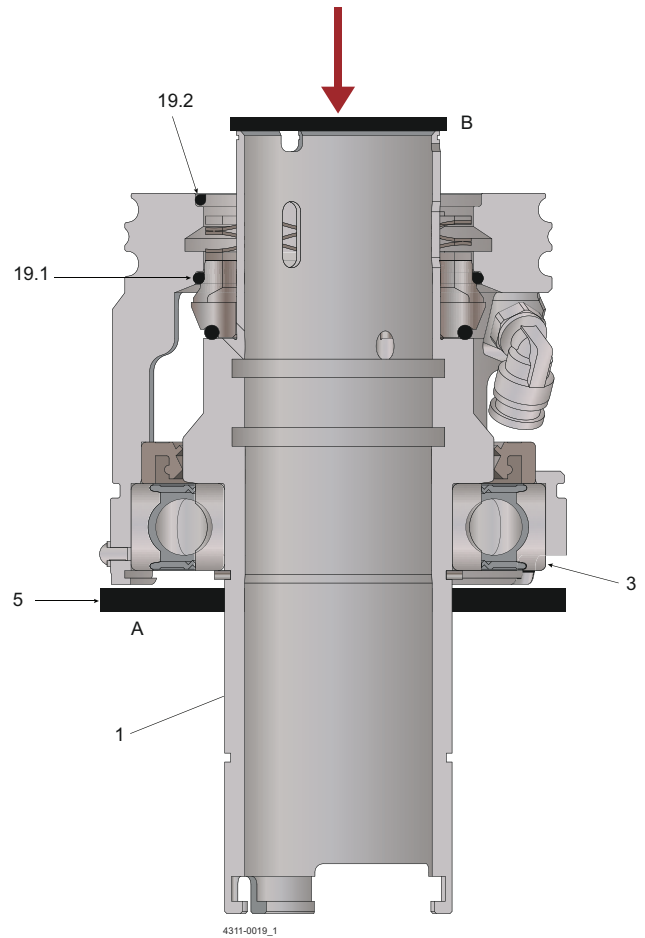

- 6 a) Push the wave spring (20) to the one side (B) and screw it out of the Seal Cartridge house (5). It is not necessary to dismantle the two rings (19-1, 19-2) – dispose of it.



Follow approved recycling procedures.

- b) Screw in the new wave spring (20) between the two rings (19-1, 19-2).
c) Press out the radial seal (8) using an appropriate ring or tool and dispose of it.



Follow approved recycling procedures.

- d) Press in the new radial seal (8) using an appropriate ring or tool – it cannot be pressed in by hands as it will tilt or bend – a controlled vertical movement from a workshop-press or the like is necessary.
e) Apply plenty of food approved grease in the entire cavity (A) in the radial seal (8).
f) Apply food approved grease to the O-ring (14-1) and mount it into the Seal Cartridge house (5). If it is difficult to keep the O-ring in place it can be stretched a little before it is mounted.

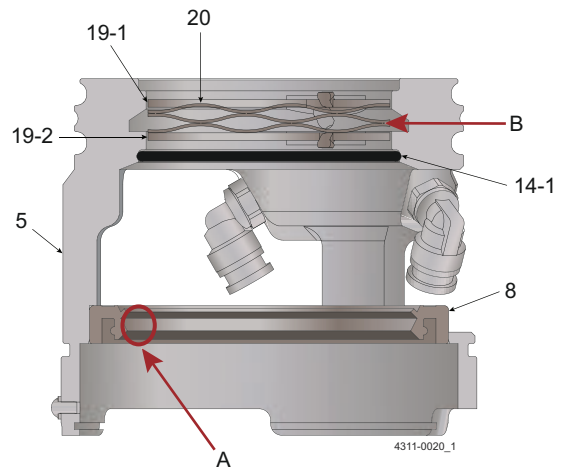

7 Take the sleeve (1) from step 5.

- a) Remove the seal faces and O-rings (10-1, 11, 12, 14-1) from the sleeve (1) and dispose of them.



Follow approved recycling procedures.

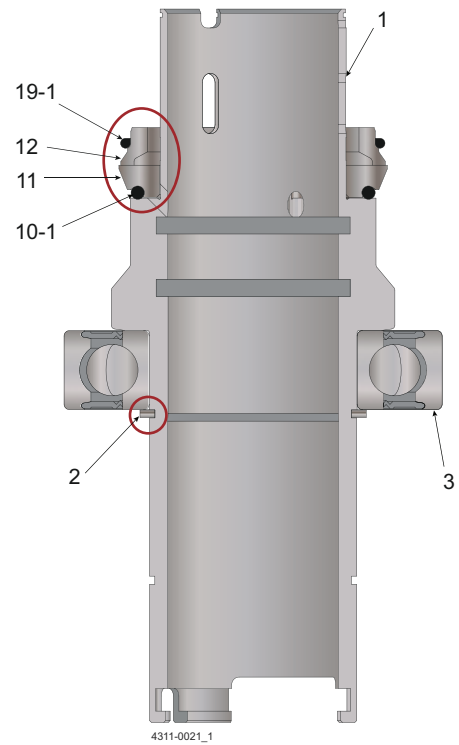

- b) Remove retainer ring (2) using a snap-ring-plier.
- c) Press out the bearing (3) and dispose of it.



Follow approved recycling procedures.

- d) Press in the new bearing (3) using a workshop-press only pressing on the inner ring of the bearing (3) (pressing on the outer ring may damage the bearing).
- e) Mount the retainer ring (2) using a snap-ring-plier.

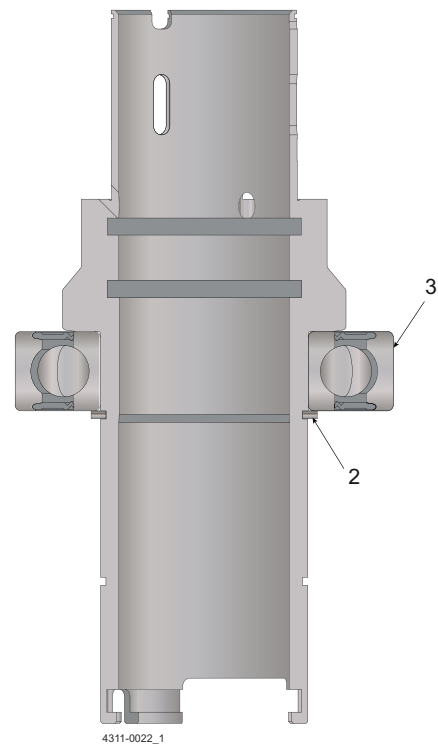

- 8
- Apply some food approved grease to the O-ring (10-1) and place it into the seal element (11) (the O-ring must not be rotated into the groove – instead stretch it a little before it is placed into the groove) and place them on the sleeve (1).
 - Clean the sealings surfaces on the seal faces (11 and 12) using with some alcohol on clean paper.
 - Place the seal face (12) on top of the seal faces (11).

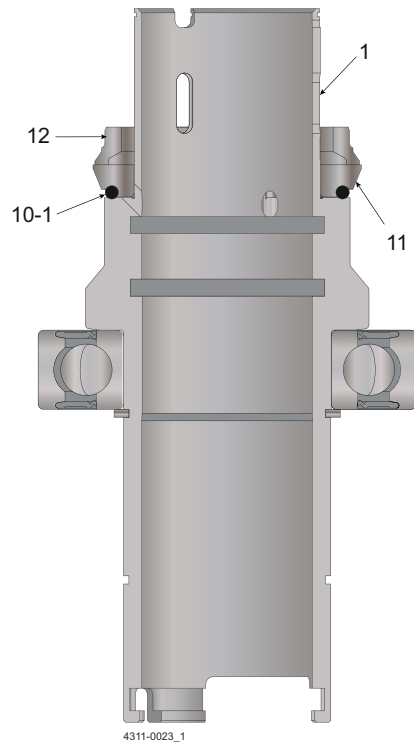

- 9
- Observe the slot (B) in the seal face (12) and the tap (1) in the ring (19-1). Position the sleeve (A) by rotating it ensuring that the tap and the slot will engage when assembled.

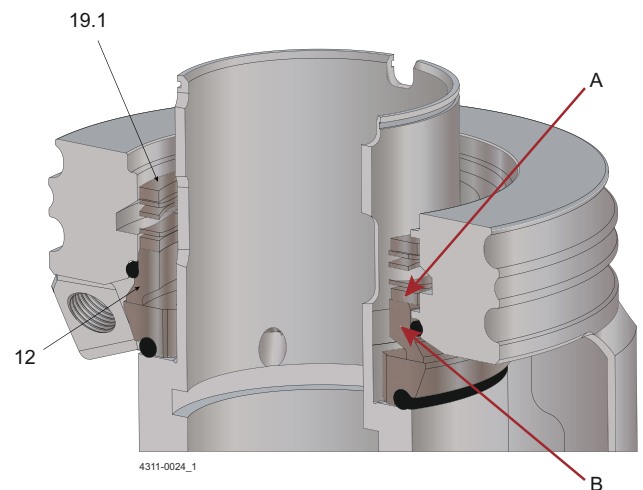

10

- a) Place the parts with the bearing (3) resting on a suitable ring (A) in a workshop-press.
- b) Place a suitable ring (B) protected by some paper or clothes, ensuring that the surface on the Seal Cartridge house (5) is not scratched or damaged.
- c) Press on the ring (B) until the bearing (3) is resting against the shoulder in the Seal Cartridge house (5).

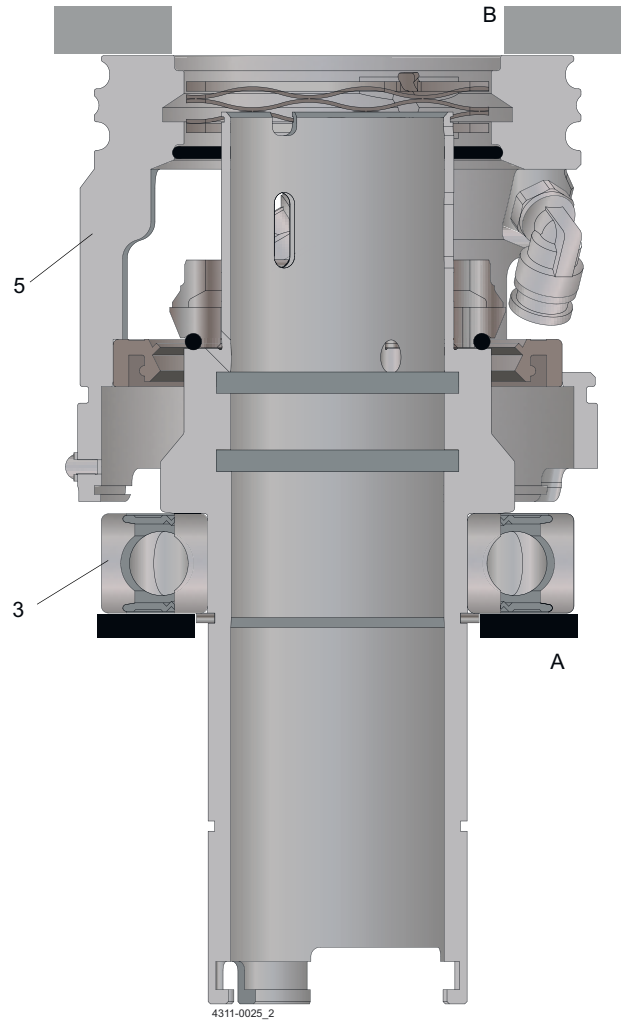

- 11**
- Screw in the retainer ring (4).
 - Add some food approved grease to the O-ring (14-2) and mount it into the groove.

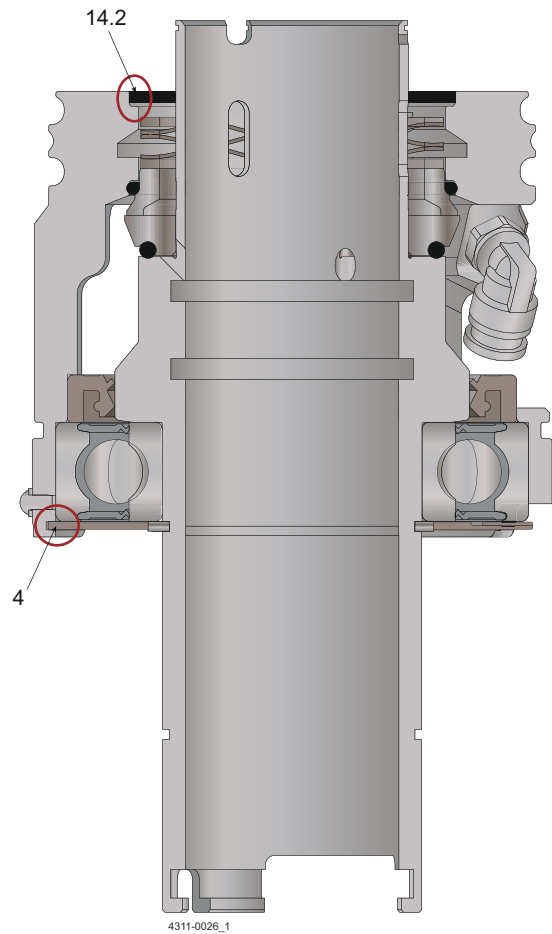

- 12**
- Orient the distance sleeve (18) enabling the tap (B) to enter slot (D) in the sealing ring (11).

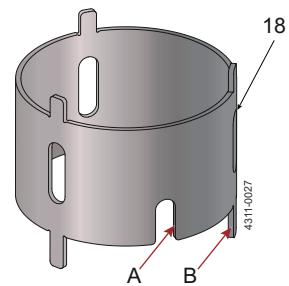

- Rotate the distance sleeve (18) (also rotating the sealing ring (11) as they are engaged) until the knot (C) on the sleeve (1) enters the groove (A) in the distance sleeve (18).

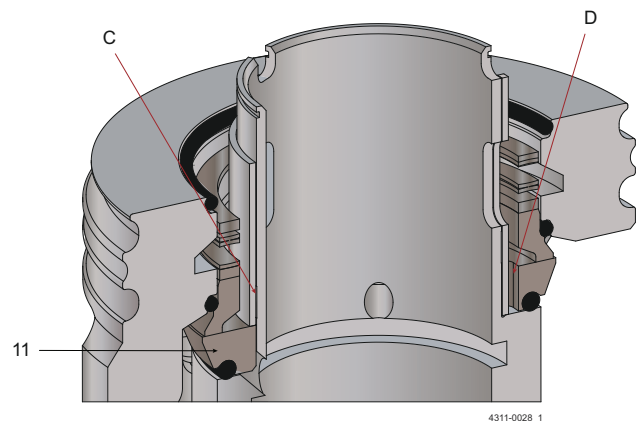

13

- a) Orientate the seal face (15) on top of the O-ring (14-2) enable the tap (B) and the groove (A) to engage when assembled.
- b) Clean the sealing surfaces on seal face (15) and on seal face (16) with some alcohol and clean paper.
- c) Orientate seal face (16) on top of seal face (15) enable the tap (C) and the groove (D) to engage when assembled.
- d) Push down the seal faces (15 and 16) compressing the spring (20) and hold them down using clean fingers (no tooling) – do not release the press as the O-ring (14-2) will rotate and/or possibly disengage.

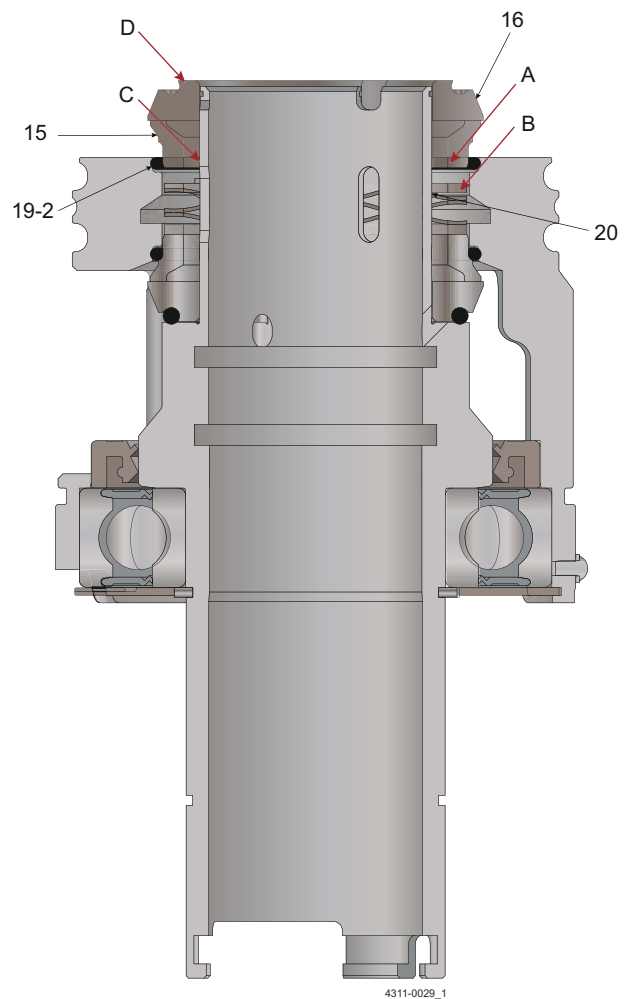

4311-0029_1

14

- a) Mount the retainer ring (17).
- b) Push down again on the seal face (16) ensuring that the retainer ring (17) is in correct position in the grooves in the sleeve (1).

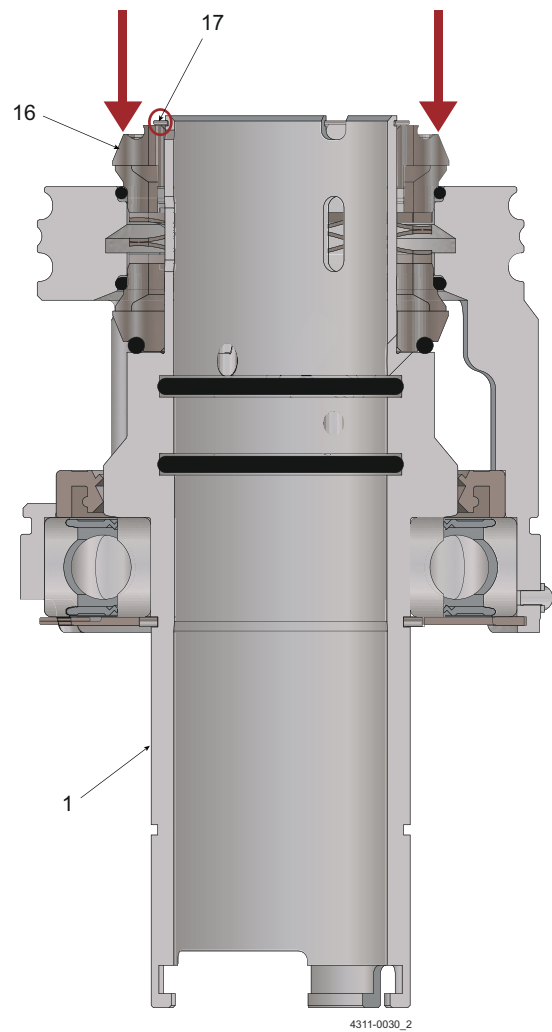

- 15 a) Apply some food approved grease to the O-rings and mount (9-1, 9-2, 10-2, 13-1, 13-2, 7).

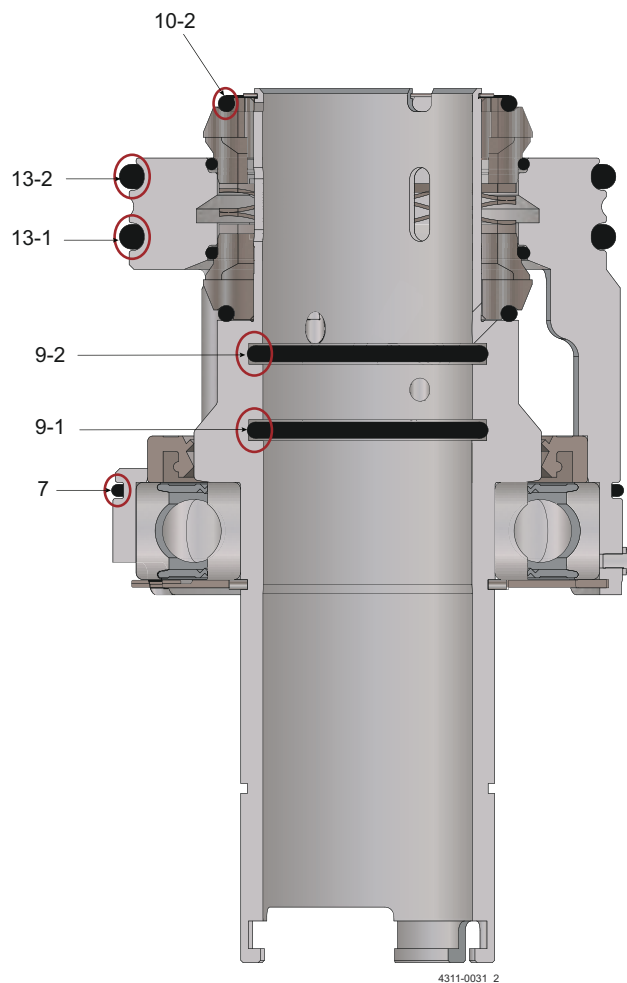

The service is now complete.

7 Technical Data

NOTE

Technical data must be observed during installation, operation and maintenance.
All personnel should be informed about the technical data.

7.1 General technical data

NOTE

All dimensions in mm/inch unless otherwise stated.

The Alfa Laval agitator is available in various configurations and is configured to solve the specific application. Therefore, specific information like weight, size, critical oscillation speed and duties can be found in the supplied Alfa Laval quotation agreement.

Important installation information about weight and mounting angle can be found on the supplied agitator name plate as shown on the illustration.

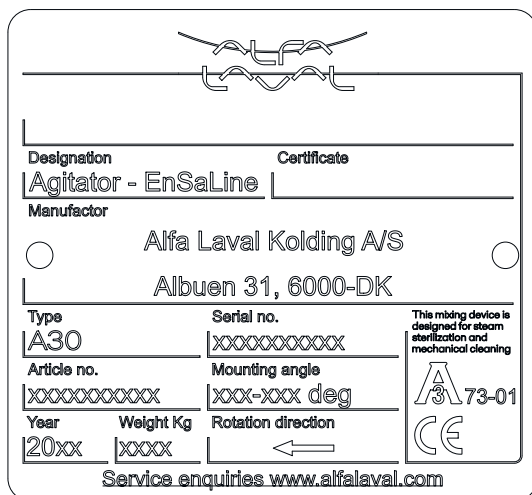

7.2 Connecting flush – seal type CD

Flush connection

In and out:	Ø8 mm/0.31 inch push-in connection
Flushing pressure max.:	2.0 bar(g)/29 psi

Flush media pressure recommendation to prevent flush media contamination by the product media

(flush media pressure > tank operating pressure)

Flushing pressure:	\geq (Tank operating pressure + 0.1 bar/1.45 psi)
--------------------	---

NOTE

Tank pressure cannot be higher than 1.9 bar(g)/27.56 psi(g) due to the maximum flushing pressure. If higher tank pressure is needed the next flush media pressure recommendation must be followed.

Flush media pressure recommendation to prevent product media contamination by the flush media

(tank operating pressure > flush media pressure)

Flushing pressure:	\leq (Tank operating pressure – 0.1 bar/1.45 psi)
--------------------	---

(Tank operating pressure – Flushing pressure) \leq 2.5 bar/36.26 psi

NOTE

If the tank pressure is more than 2.5 bar(g)/36.26 psi(g) greater than the flushing pressure, there will be a risk of dry running on the primary seal faces when the seal faces are not submerged. When the seal faces are submerged there is no limit on the pressure difference during operation

Flush media flow recommendation

Flushing flow rate:	$>$ 0.25 ltr/min/0.066 gpm
---------------------	----------------------------

Lower flushing flow rate is allowed as long as the temperature difference between in- and outlet is $<$ 10°C/18°F

Flush media type recommendation

- White oils
- Water
- Wet steam
- Alcohol

- Always use appropriately in- and outlet temperatures given for current seal elastomers
- Inlet temperature to be 15°C/27°F below actual fluid boiling point (temperature and pressure dependent)
- Always use wet steam (H₂O) if steam is used as flushing fluid
- Inlet temperature ≤ 121°C/250°F

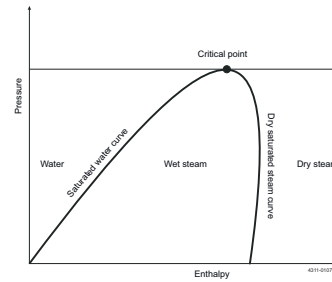

Sterile barrier at seal type D and CD:

- Use a sterile supply system with preferred sterilization temperature and water / wet steam as flush type and ensure that above recommendations are followed

NOTE

Alfa Laval recommends installing a pressure relief valve to ensure pressure never exceeds specifications.

Alfa Laval recommends installing a non-return valve onto the inlet connection, to ensure that the seal never runs dry.

If higher flushing pressure is desired, please contact Alfa Laval for advice.

7.3 Tightening torques for bolt connections



Use Loctite® before fastening.
Do **NOT** use air powered tools.

Nm											
M4	M5	M6	M8	M10	M12	M14	M16	M18	M20	M22	M24
3	6	11	26	51	88	141	218	308	439	582	724

ft-lb											
M4	M5	M6	M8	M10	M12	M14	M16	M18	M20	M22	M24
2.21	4.43	8.11	19.19	37.62	64.90	104.04	160.82	227.16	324.03	429.38	534.44

7.4 Spider coupling

Tooth thickness (mm/inch):

	Agitator type	
	A30 mm/inch	A45 mm/inch
Ynew:	10.9/0.43	13.3/0.52
Ymin:	7.9/0.31	10.3/0.41

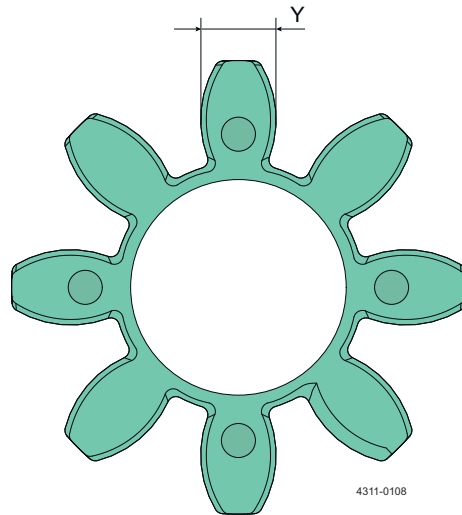

4311-0108



During check of spider ensure that all dust is removed before reassembly.

7.5 Storage

Store the agitator in dry and clean environments.

Rotate shaft every second week to ensure seal faces do not stick together.

This page is intentionally left blank.

8 Spare Parts

For every delivered Alfa Laval Product, a spare part list is available.

This spare part list contains a range of the most common wear parts for the machinery. If any component not mentioned is required, please contact your local Alfa Laval representative for availability.

You can find our spare part catalogue at <https://hygienicfluidhandling-catalogue.alfalaval.com>.

Always use Alfa Laval genuine spare parts. The warranty of Alfa Laval products is dependent on use of Alfa Laval genuine spare parts.

8.1 Ordering Spare Parts

When ordering spare parts, please always state:

1. Serial number (if available)
2. Item number/spare part number (if available)
3. Capacity or other relevant identification

8.2 Alfa Laval Service

Alfa Laval is represented in all larger countries of the world.

Do not hesitate to contact your local Alfa Laval representative, with any questions or requirement of spare parts for Alfa Laval equipment.

8.3 Warranty - definition



The rules of Intended use are absolute. Use of the supplied Alfa Laval product is allowed only when in compliance with the technical data supplied with the Intended use.

Differing utilisation, other than agreed with Alfa Laval Kolding A/S, exclude any liability and warranty.

No modification or alteration of the supplied Alfa Laval product is allowed, unless explicit permission is granted by Alfa Laval Kolding A/S.



Liability and warranty are excluded:

- If advice and instruction of operating instructions are ignored
- For incorrect operation or for insufficient maintenance of the supplied Alfa Laval product
- For any kind of change of function of the supplied Alfa Laval product without prior written agreement by Alfa Laval Kolding A/S
- If supplied Alfa Laval product is modified by non-authorized persons
- If using the supplied Alfa Laval product without attention of appropriate safety regulations, (see [Safety](#) on page 7)
- If protection equipment is not used and vessel process / ancillary equipment is not brought to a standstill
- If the supplied Alfa Laval product and ancillary parts are not properly maintained (to be executed in intervals and including fitting of prescribed replacement parts)

When exchanging parts, only original replacement parts, released from the manufacturer, must be used.

9 Parts Lists and Exploded Views

9.1 Agitator overview

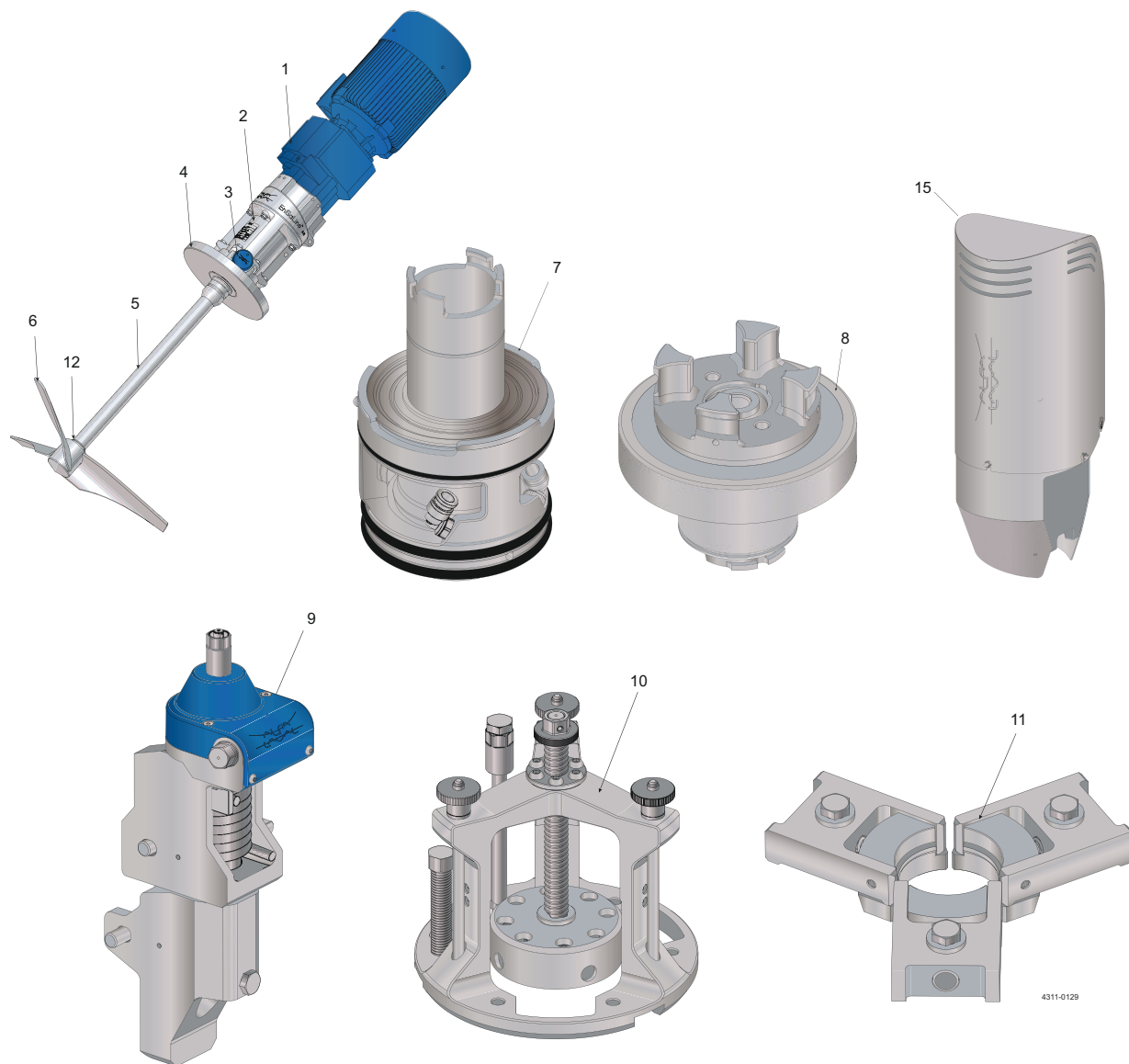

Pos.	Qty.	Denomination
1	1	Drive unit
2	1	Housing
3	-	Clariot
4	1	Welding flange
5	1	Drive shaft
6	1	Impeller
7	1	Complete Cartridge Spare unit
8	1	Top bearing assembly

Pos.	Qty.	Denomination
9	1	Hinge jack
10	1	Center jack
11	3	Shaft retainer
12	1	O-ring, shaft-impeller
13	1	Wrench Service tool
14		Hex key Service tool
15		Shroud

9.2 Drive unit

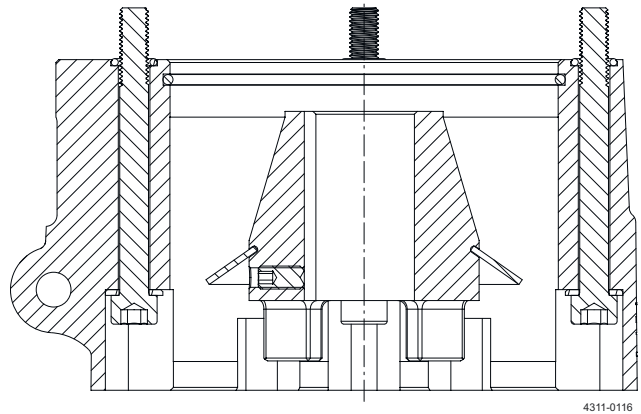
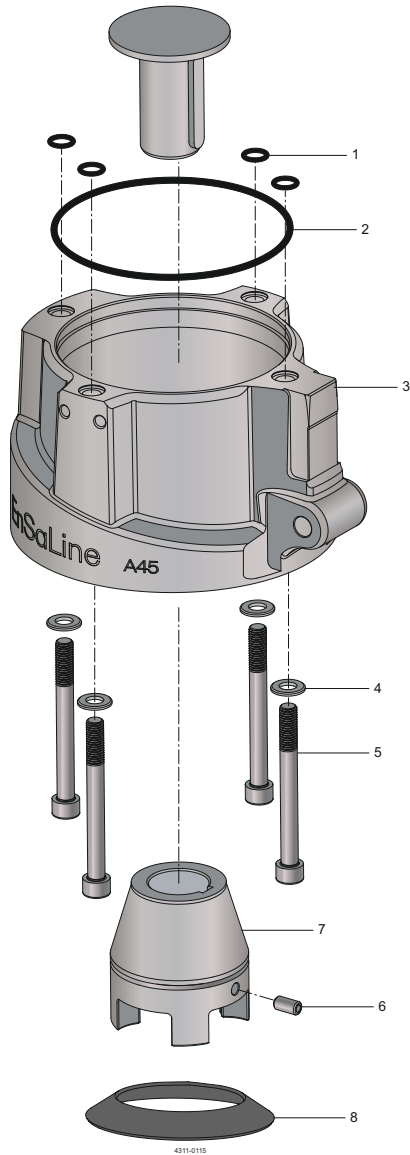

Pos.	Qty.	Denomination
1	4	O-ring
2	1	O-ring
3	1	Drive unit flange
4	4	Washer

Pos.	Qty.	Denomination
5	4	Screw
6	1	Coupling
7	1	Set screw
8	1	Oil trap

NOTE

Find unique item numbers and item numbers for Spare part and Service kits in the Spare part manual available from the on-line [Alfa Laval product catalogue Anytime](#) or in the [Close at hand spare part catalogue](#).

9.3 Drive train

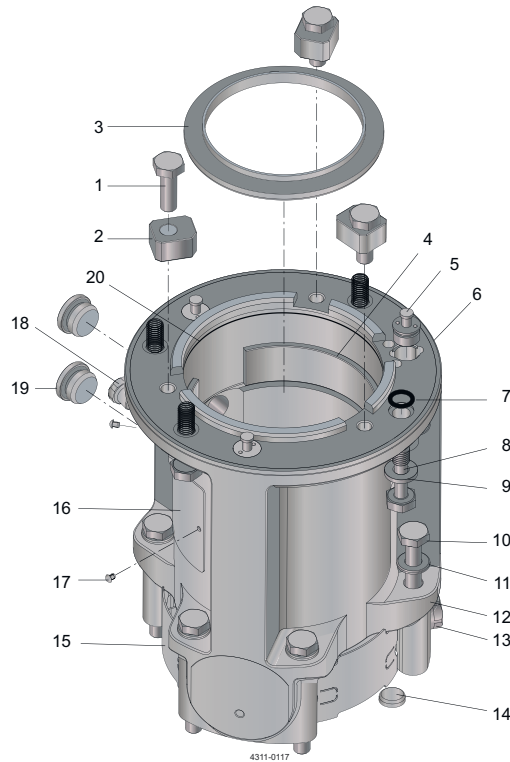

Pos.	Qty.	Denomination
1	3	Screw
2	3	Spacer block
3	1	Spacer
4	1	Oil trap
5	3	Pin, Mushroom
6	1	O-ring
7	4	O-ring
8	4	Screw
9	4	Washer
10	6	Screw

Pos.	Qty.	Denomination
11	6	Washer
12	1	Housing
13	1	O-ring
14	1	Cap, Sealing Push-In
15	3	Cover
16	1	Name plate
17	2	Rivet
18	1	Air vent
19	2 ¹	Plug screw
20	1	O-ring

¹ Qty 1 for A30

¹ Qty 1 for A30

NOTE

Find unique item numbers and item numbers for Spare part and Service kits in the Spare part manual available from the on-line [Alfa Laval product catalogue Anytime](#) or in the [Close at hand spare part catalogue](#).

9.4 Top bearing assembly size A45

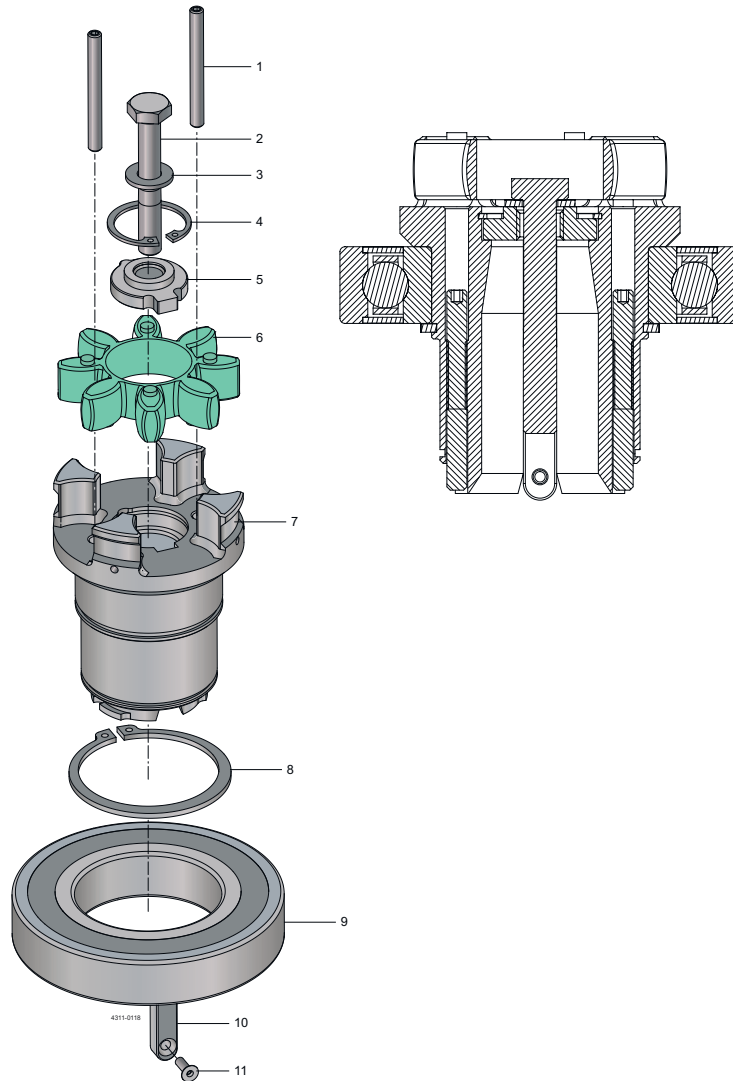

Pos.	Qty.	Denomination
1	2	Set screw
2	1	Screw
3	1	Washer
4	1	Retainer ring
5	1	Retainer plate
6	1	Spider

Pos.	Qty.	Denomination
7	1	Coupling
8	1	Retainer ring
9	1	Bearing
10	1	Parallel key
11	1	Screw

NOTE

Find unique item numbers and item numbers for Spare part and Service kits in the Spare part manual available from the on-line [Alfa Laval product catalogue Anytime](#) or in the [Close at hand spare part catalogue](#).

9.5 Top bearing assembly, size A30

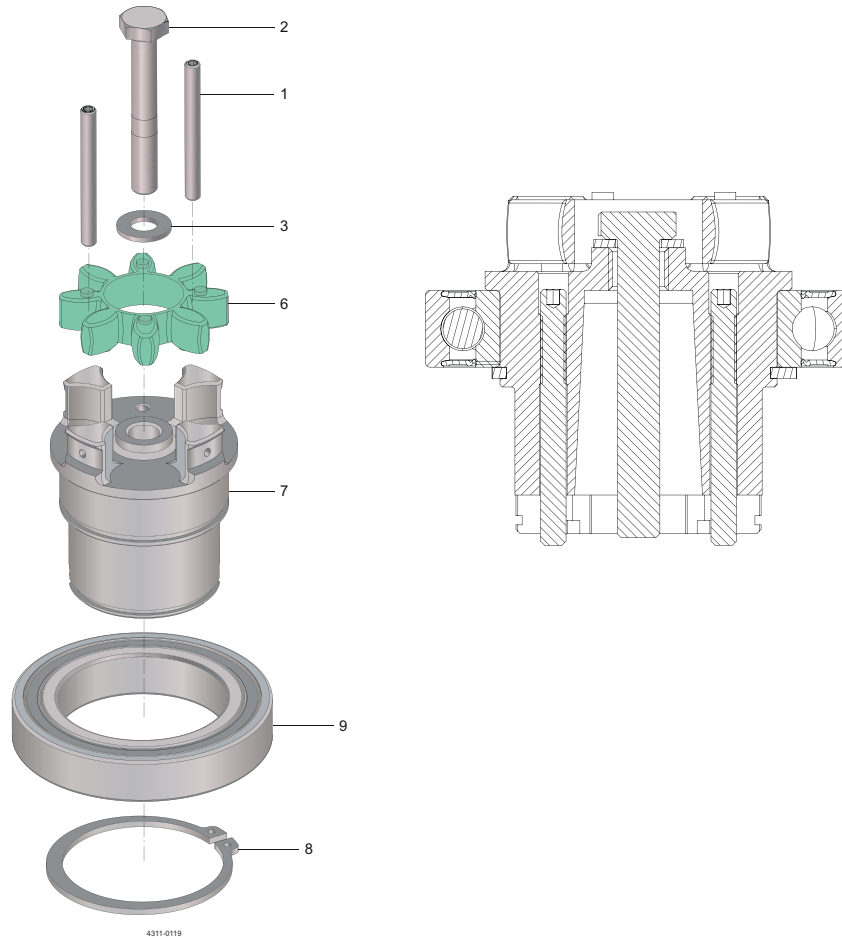

Pos.	Qty.	Denomination
1	2	Set screw
2	1	Screw
3	1	Washer
6	1	Spider

Pos.	Qty.	Denomination
7	1	Coupling
8	1	Retainer ring
9	1	Bearing

NOTE

Find unique item numbers and item numbers for Spare part and Service kits in the Spare part manual available from the on-line [Alfa Laval product catalogue Anytime](#) or in the [Close at hand spare part catalogue](#).

9.6 Cartridge Double seal (CD), size A45

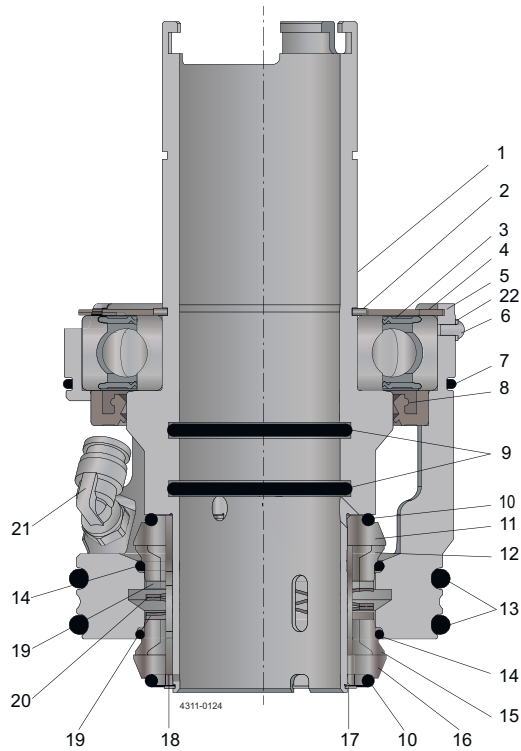

Pos.	Qty.	Denomination
1	1	Sleeve, seal
2	1	Retainer ring
3	1	Bearing
4	1	Retainer ring
5	1	House, seal
6	1	Pin, grooved
7	1	O-ring
8	1	Radial seal
9	2	O-ring
10	2	O-ring
11	1	Seal face

Pos.	Qty.	Denomination
12	1	Seal face
13	2	O-ring
14	2	O-ring
15	1	Seal face
16	1	Seal face
17	1	Retainer ring
18	1	Sleeve, distance
19	2	Ring, seal
20	1	Spring
21	2	Push-In-Fitting
22	1	Washer

NOTE

Find unique item numbers and item numbers for Spare part and Service kits in the Spare part manual available from the on-line [Alfa Laval product catalogue Anytime](#) or in the [Close at hand spare part catalogue](#).

9.7 Cartridge Wet Seal (CWS), size A45

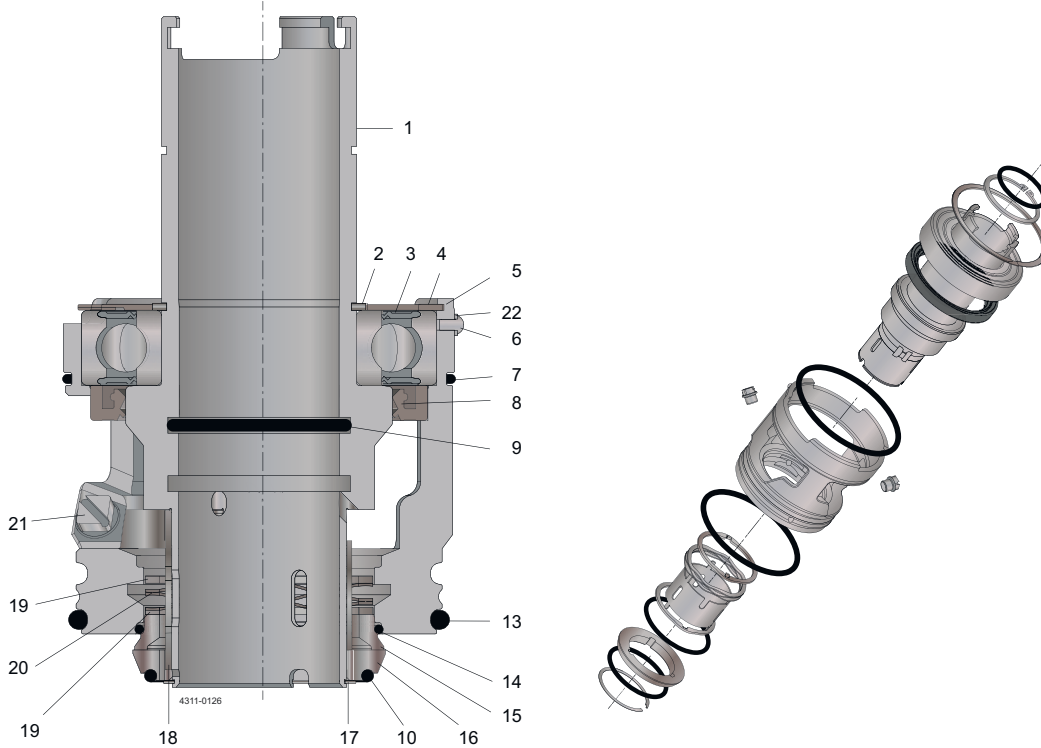

Pos.	Qty.	Denomination
1	1	Sleeve, seal
2	1	Retainer ring
3	1	Bearing
4	1	Retainer ring
5	1	House, seal
6	1	Pin, grooved
7	1	O-ring
8	1	Radial seal
9	1	O-ring
10	1	O-ring

Pos.	Qty.	Denomination
13	1	O-ring
14	1	O-ring
15	1	Seal face
16	1	Seal face
17	1	Retainer ring
18	1	Sleeve, distance
19	2	Ring, seal
20	1	Spring
21	2	Plug
22	1	Washer

NOTE

Find unique item numbers and item numbers for Spare part and Service kits in the Spare part manual available from the on-line [Alfa Laval product catalogue Anytime](#) or in the [Close at hand spare part catalogue](#).

9.8 Cartridge Double seal (CD), size A30

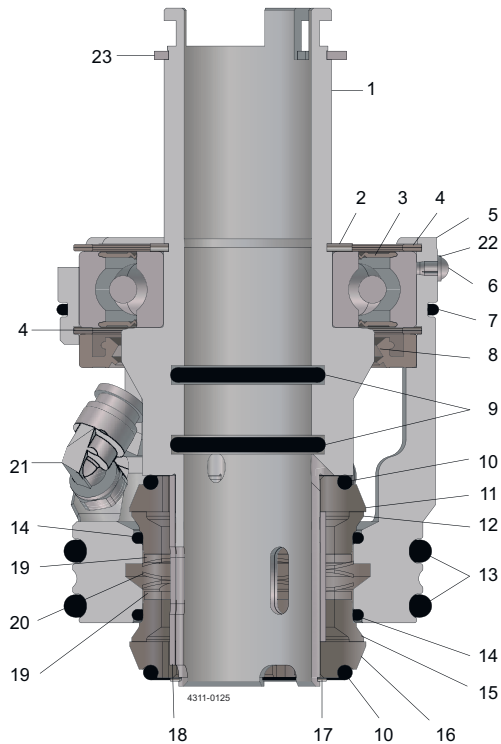

Pos.	Qty.	Denomination
1	1	Sleeve, seal
2	1	Retainer ring
3	1	Bearing
4	1	Retainer ring
5	1	House, seal
6	1	Pin, grooved
7	1	O-ring
8	1	Radial seal
9	2	O-ring
10	2	O-ring
11	1	Seal face
12	1	Seal face

Pos.	Qty.	Denomination
13	2	O-ring
14	2	O-ring
15	1	Seal face
16	1	Seal face
17	1	Retainer ring
18	1	Sleeve, distance
19	2	Ring, seal
20	1	Spring
21	2	Push-In-Fitting
22	1	Washer
23	1	Retainer ring

NOTE

Find unique item numbers and item numbers for Spare part and Service kits in the Spare part manual available from the on-line [Alfa Laval product catalogue Anytime](#) or in the [Close at hand spare part catalogue](#).

9.9 Cartridge Wet Seal (CWS), size A30

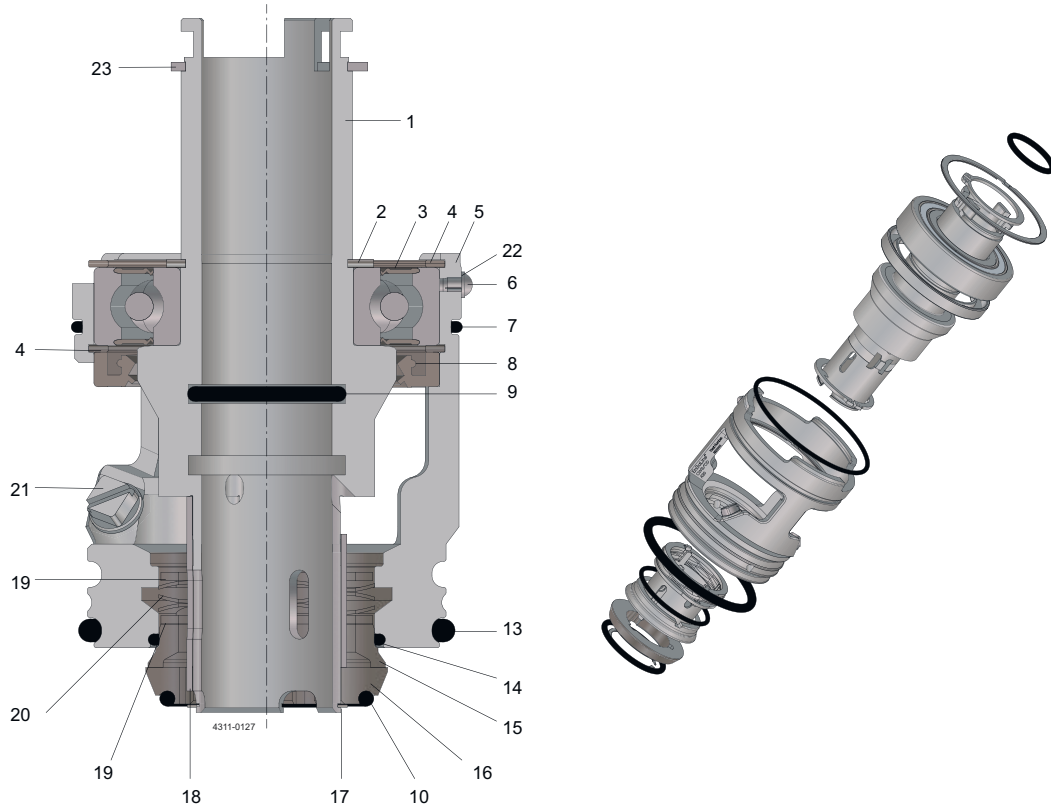

Pos.	Qty.	Denomination
1	1	Sleeve, seal
2	1	Retainer ring
3	1	Bearing
4	1	Retainer ring
5	1	House, seal
6	1	Pin, grooved
7	1	O-ring
8	1	Radial seal
9	1	O-ring
10	1	O-ring

Pos.	Qty.	Denomination
13	1	O-ring
14	1	O-ring
15	1	Seal face
16	1	Seal face
17	1	Retainer ring
18	1	Sleeve, distance
19	2	Ring, seal
20	1	Spring
21	2	Plug
22	1	Washer
23	1	Retainer ring

NOTE

Find unique item numbers and item numbers for Spare part and Service kits in the Spare part manual available from the on-line [Alfa Laval product catalogue Anytime](#) or in the [Close at hand spare part catalogue](#).

9.10 Hinge jack

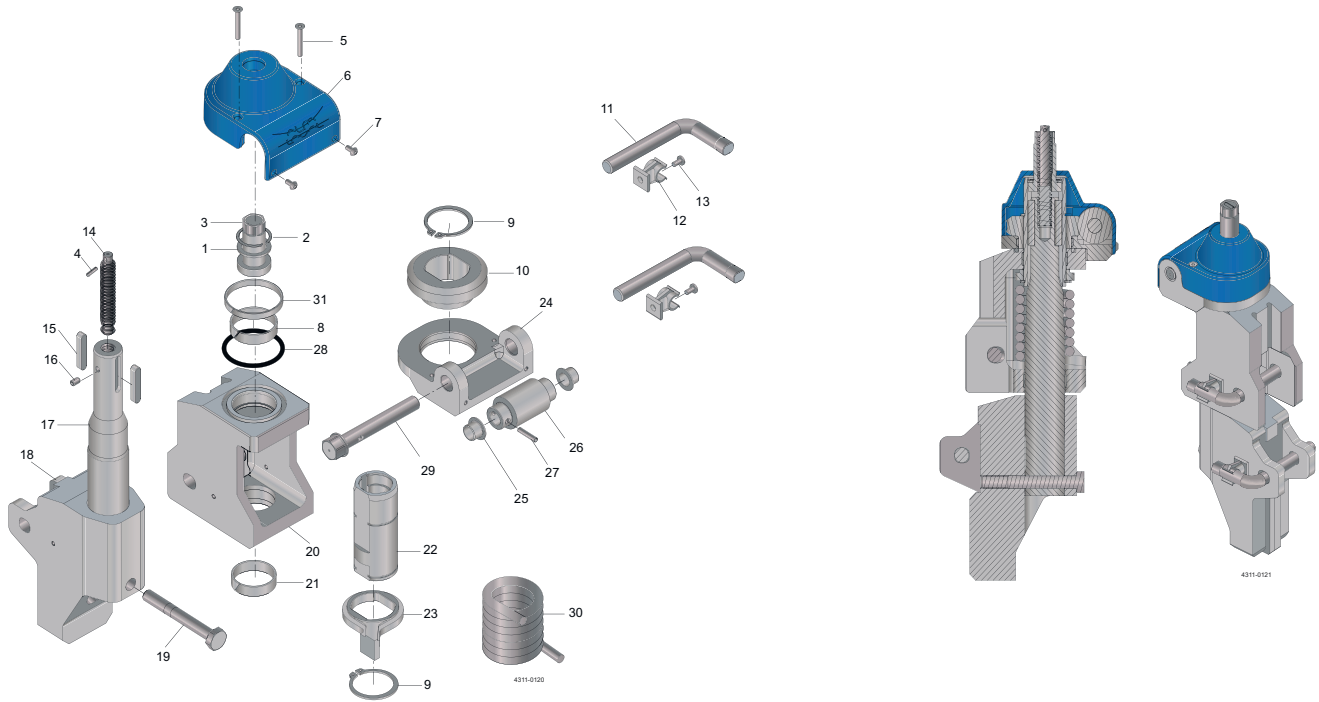

Pos.	Qty.	Denomination
1	2	Back plate
2	1	Retainer ring
3	1	Nut
4	1	Pin, slotted spring
5	2	Screw
6	1	Worm gear cap
7	2	Screw
8	1	Guide ring
9	2	Retainer ring
10	1	Worm gear wheel
11	2	Pin
12	2	Pipe clamp
13	2	Screw
14	1	Threaded rod
15	2	Parallel key
16	1	Set screw

Pos.	Qty.	Denomination
17	1	Center shaft
18	1	Base bracket
19	1	Screw
20	1	Swivel bracket
21	1	Guide ring
22	1	Pully
23	1	Torque arm
24	1	Worm gear housing
25	2	Sleeve bearing
26	1	Worm screw
27	1	Pin, slotted spring
28	1	O-ring
29	1	Worm screw shaft
30	1	Torsion spring
31	1	Guide ring

NOTE

Find unique item numbers and item numbers for Spare part and Service kits in the Spare part manual available from the on-line [Alfa Laval product catalogue Anytime](#) or in the [Close at hand spare part catalogue](#).

9.11 Center jack

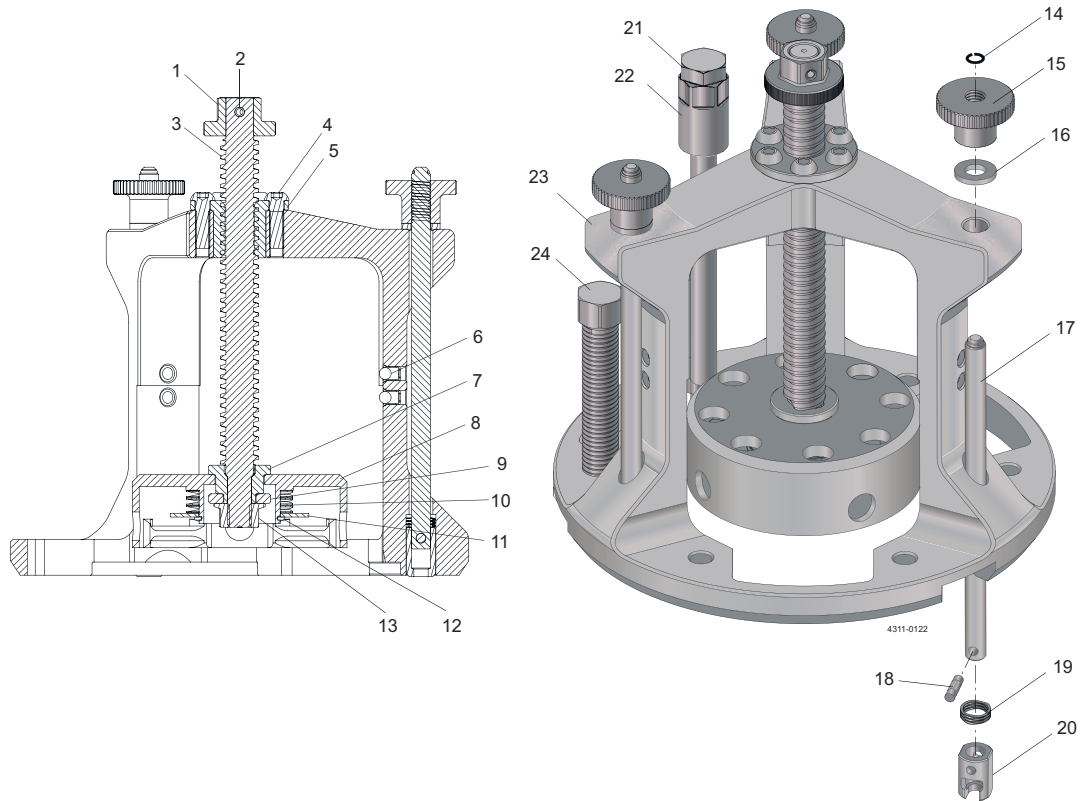

Pos.	Qty.	Denomination
1	1	Knurled screw head
2	1	Pin, slotted spring
3	1	Threaded rod
4	6	Screw
5	1	Thread insert
6	6	Spring plunger
7	1	Swivel bushing
8	1	Swivel joint
9	1	Swivel washer
10	1	Wave spring
11	1	Disc
12	1	Retainer ring

Pos.	Qty.	Denomination
13	1	Flange nut
14	3	Snap ring
15	3	Knurled nut high
16	3	Washer
17	3	Stud
18	3	Pin, grooved
19	3	Wave spring
20	3	Mushroom connector
21	1	Screw
22	1	Nut special
23	1	Center jack frame
24	1	Screw

NOTE

Find unique item numbers and item numbers for Spare part and Service kits in the Spare part manual available from the on-line [Alfa Laval product catalogue Anytime](#) or in the [Close at hand spare part catalogue](#).

9.12 Shaft retainer

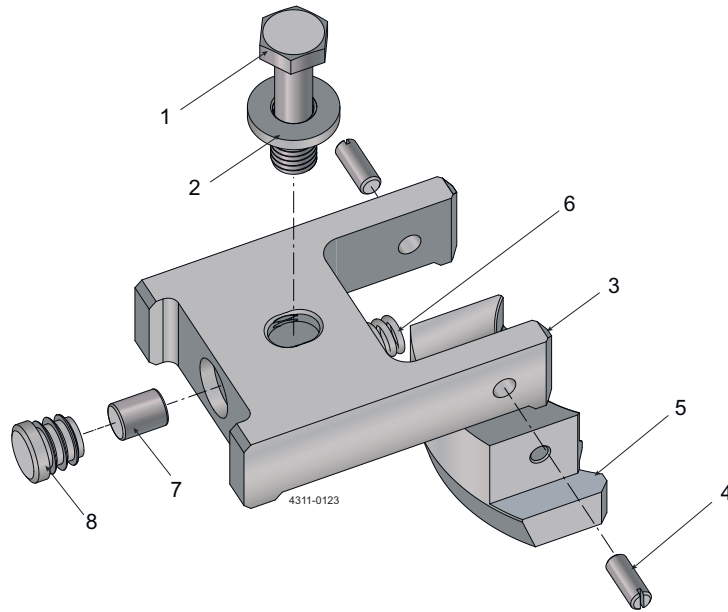

Pos.	Qty.	Denomination
1	1	Screw
2	1	Washer
3	1	Shaft retainer arm
4	2	Set screw

Pos.	Qty.	Denomination
5	1	Shaft retainer clamp
6	1	Spring
7	1	Magnet
8	1	Plug

NOTE

Find unique item numbers and item numbers for Spare part and Service kits in the Spare part manual available from the on-line [Alfa Laval product catalogue Anytime](#) or in the [Close at hand spare part catalogue](#).

10 Appendix

10.1 Drive unit instructions

The drive unit is supplied by sub supplier and all important installation requirement is transferred to the agitator instruction manual. For further information regarding maintenance and storage of the drive unit please find the drive unit instruction manual by below links.

For agitators with gears please find the drive unit instruction manual by below link:

<https://www.nord.com/cms/en/documentation/manuals/manuals.jsp>

and select document "Gear Units and Geared Motor B1000".